

Training Recurrent Networks

Recurrent Network

- A recurrent network is one in which there is feedback from a neuron's output to its input.
- Various models exist:
 - Jordan Network (feedback from net output to input)
 - Elman Network ("partially recurrent": feedback from internal state output to input)
 - Hopfield Network (a special class, studied later)

Jordan vs. Elman Networks

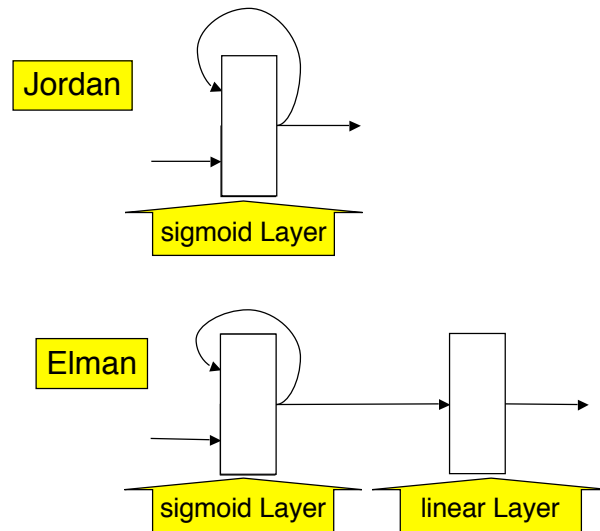

Elman Networks

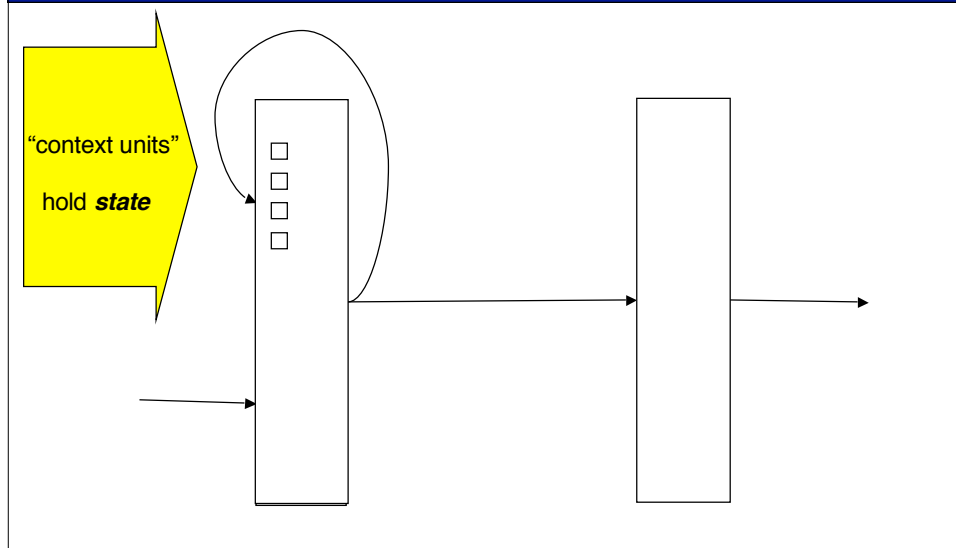

Reference

- Elman, J. L. (1990). Finding structure in time. *Cognitive Science*, 14:179-211.
- Neural Networks: Automata and Formal Models of Computation. Mikel L. Forcada, <http://www.dlsi.ua.es/~mlf/nnafmc/pbook/pbook.html>

Elman PRNN for Bankruptcy Prediction (Oak Ridge Nat'l Lab, Grady, et al.)

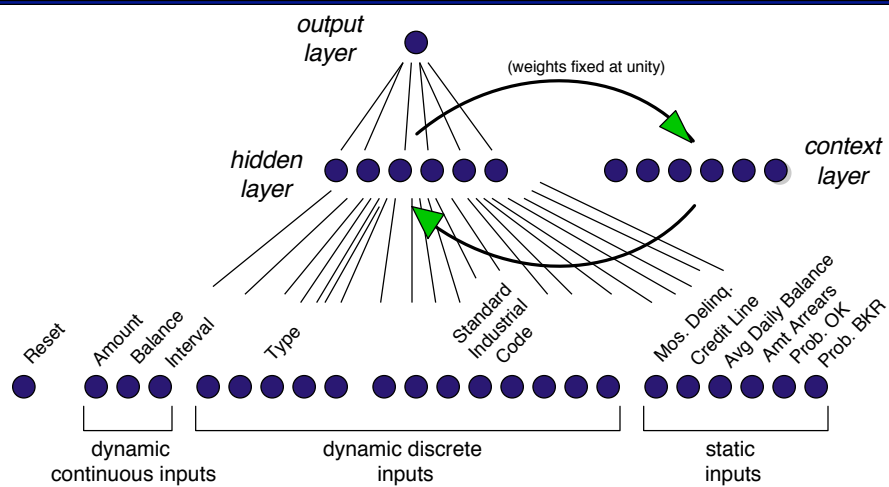

How to Train an Elman Network?

- One way:
 - Initialize the state values to *nominal*.
 - Repeat
 - Simulate one step of the network.
 - Compute the actual output.
 - Backpropagate the error.
 - Adjust the weights.
 - Compute the next state.
 - Until the error is sufficiently low.

Training Feedback Weights

- Elman Schematic

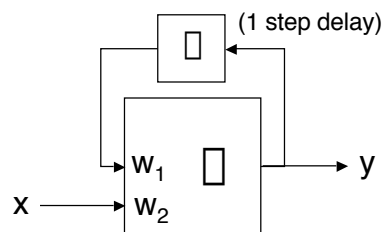

$$y(k) = w_1 y(k-1) + w_2 x(k)$$

Training Feedback Weights

$$y(k) = w_1 y(k-1) + w_2 x(k)$$

$$\partial/\partial w_2 y(k) = x(k)$$

$$\partial/\partial w_1 y(k)$$

$$= \partial/\partial w_1 w_1 y(k-1)$$

$$= y(k-1) + w_1 \partial/\partial w_1 y(k-1) \quad [\text{derivative of a product}]$$

$$= y(k-1) + y(k-2) + w_1 \partial/\partial w_1 y(k-2) \quad [\text{a recurrence}]$$

$$= y(k-1) + y(k-2) + y(k-3) + \dots$$

Conclusion: The sensitivities will depend on all previous values of the output.

Demos of Elman Training

- Two demos:
 - Matlab appelm1
 - NAS demo 11.2

Elman Demo (appelm1)

In this demo, an Elman network is trained to track the **amplitude** of a sine wave, by training on a signal of two different amplitudes.

Training

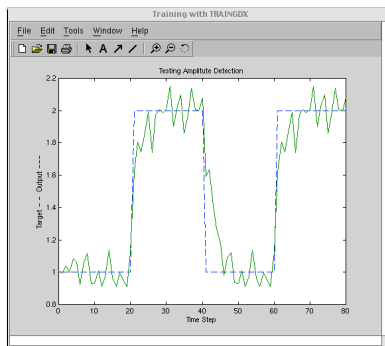

Elman Demo (appelm1)

Training MSE plot

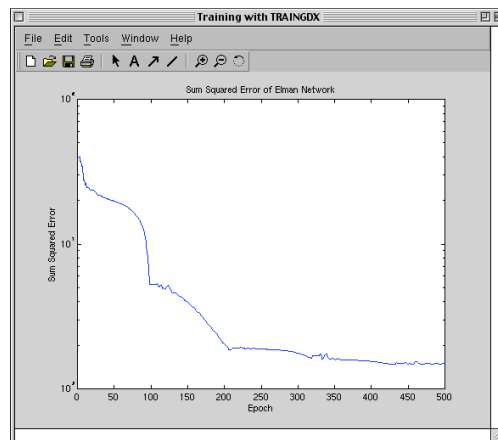

Other Possible Ways to Train an Elman Network

- BPPT (Backpropagation Through Time, seen last time) would be another way: unroll the network some large number of levels, backpropagate, average the weight changes over the **unrolled** stages to get a single set of weight changes.
- (See NAS demo 11.3.)

Real-Time Recurrent Learning (RTRL)

see <http://www.dlsi.ua.es/~mlf/nnafmc/pbook/node29.html>

- another approach to training recurrent networks, due to Williams and Zipser (1989, 1995)
- No “unrolling” is necessary
- “dual” of BPPT? (NAS)
- Later shown to be a special case of EKF (Extended Kalman Filter)
- Gradient derivatives (as well as state) at time t are computed in terms of their values at time t-1.
- Here x is the state, g' is the derivative of the activation function, x is the error, and u is the external input.

$$\frac{\partial x_i[t]}{\partial W_{kl}^{xx}} = g'(\Xi_i[t]) \left(\delta_{ik} x_l[t] + \sum_{j=1}^{n_X} W_{ij}^{xx} \frac{\partial x_j[t-1]}{\partial W_{kl}^{xx}} \right),$$
$$\Xi_i[t] = \sum_{j=1}^{n_X} W_{ij}^{xx} x_j[t-1] + \sum_{j=1}^{n_U} W_{ij}^{xu} u_j[t] + W_i^x$$