

A decorative header consisting of two horizontal lines: a thick green line on top and a thin blue line below it.

Computer Architecture

Computer Architecture

- A computer is essentially a large collection of **finite-state machines**.
- A common clock is used for all.
- The machines intercommunicate by the output of one machine being the input to another.
- Combinational logic can be interposed between output and input to affect data transformations.

Computer Architecture

- We will work with a simulated tutorial architecture:

ISC: Incredibly Simple Computer

The ISC

- ISC is an example of a
RISC (Reduced Instruction Set Computer),
as opposed to a
CISC (Complex Instruction Set Computer)

ISC Design

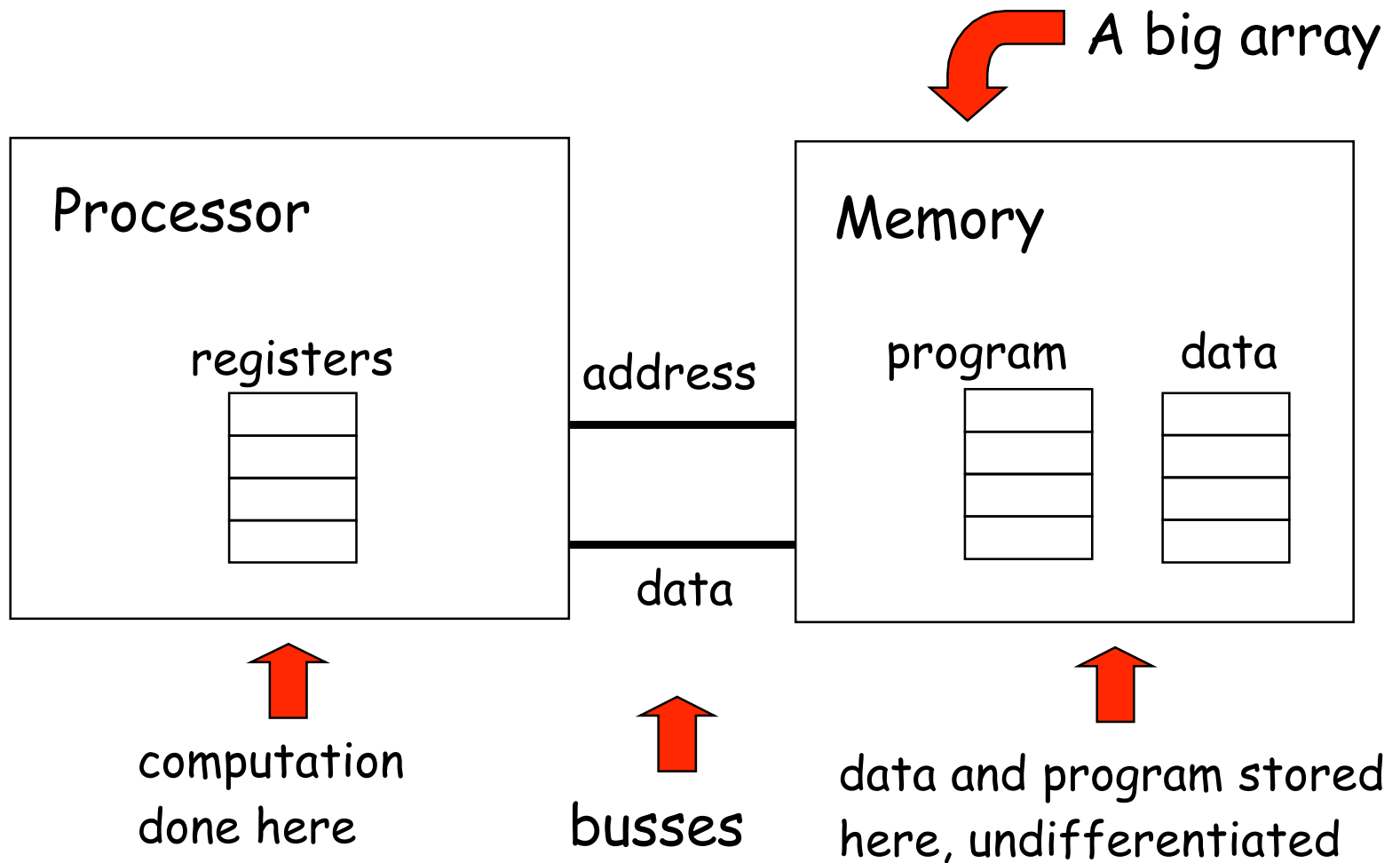

ISC Processor Components (1)

- **General Registers:** Hold operands and results, and addresses for jumps in program.
- **IR (Instruction Register)** holds currently executing instruction.
- **IP (Instruction Pointer):** Holds address of next instruction.
- **MDR (Memory Data Register)** holds data en-route to/from memory.
- **MAR (Memory Address Register)** holds address of memory location for data.

ISC Processor Components (2)

- **ALU** (Arithmetic-Logic Unit) Combinational unit performing addition, subtraction, logical operations, shifting, etc.
- **ALU registers:** Registers holding operands and results for ALU
- **Control sequencer:** Finite-state machine sequencing register and 3-state strobes, based upon the contents of the IR (Instruction Register)

ISC Processor Structure

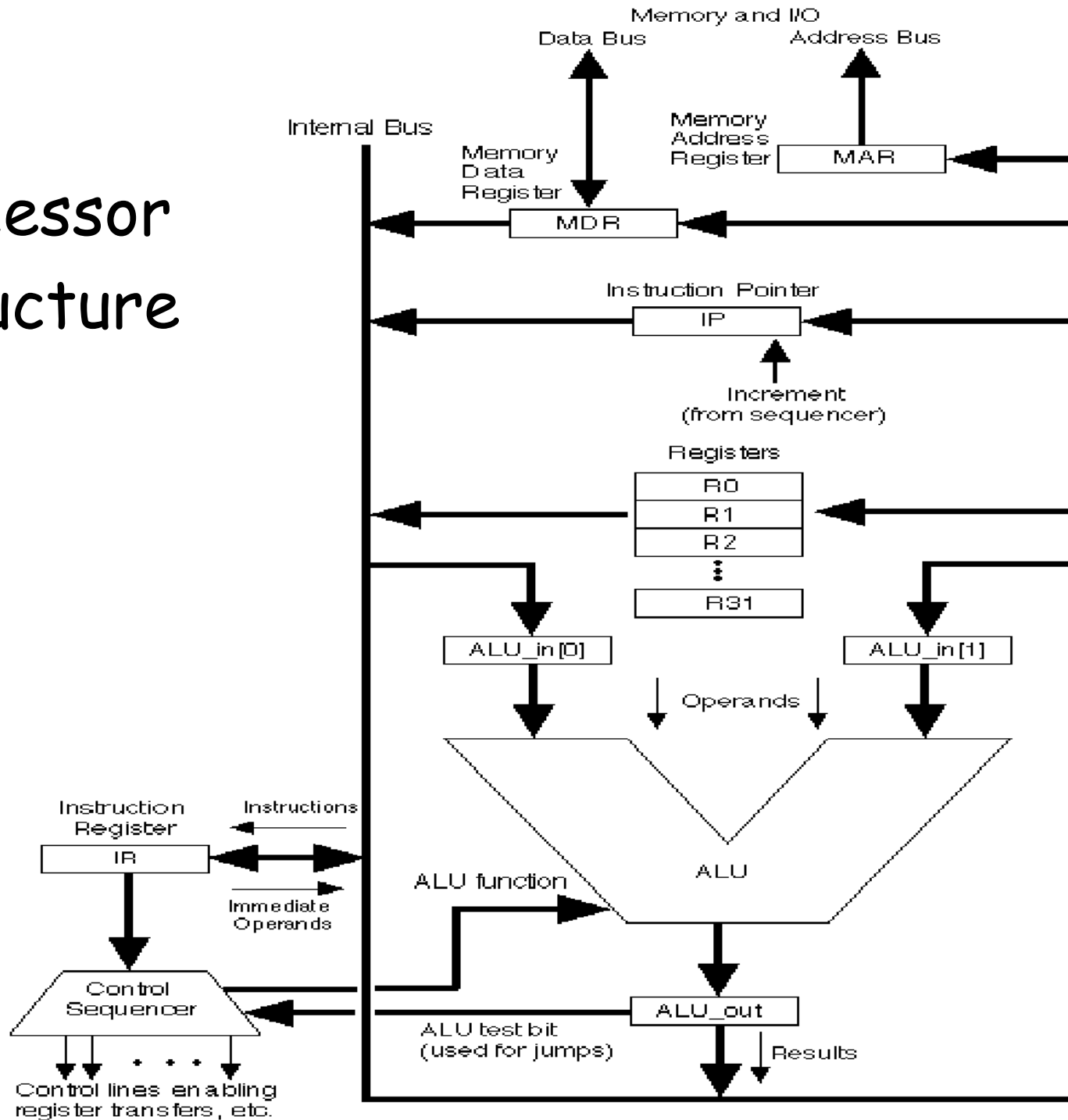

Instruction Dichotomies

- Instructions that access memory ("memory access" instructions)
- Instructions that include an operand in the instruction itself ("immediate" instructions)
- Instructions that change instruction location ("jump" instructions)

Non-memory
access
instructions

`add Ra Rb Rc`

register indices
(absolute or symbolic)

`reg[Ra] = reg[Rb] + reg[Rc];`

similarly for:

sub

mul

div

and

or

comp

shr

shl

"Immediate"
instructions

C is a constant

It can be intended
for arithmetic,
logic, or as an
address.

load immediate:

$lim\ Ra\ C$

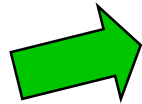

$Reg[Ra] = C;$

add immediate

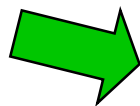

$aim\ Ra\ C$

$Reg[Ra] += C;$

Memory access instructions

The address to be used is in one of the general registers.

load:

load *Ra Rb*

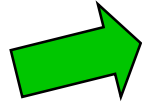

`reg[Ra] = mem[reg[Rb]];`

store:

store *Ra Rb*

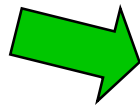

`mem[reg[Ra]] = reg[Rb];`

Jump instructions

The address to be jumped to is in one of the general registers.

jump-if-equal:



```
jeq Ra Rb Rc
```

Jump to address in Ra

if $\text{reg}[Rb] == \text{reg}[Rc]$

Similarly for:

```
jne jlt  
jgt jlte  
jgte
```

Jump instructions

The address
to be jumped to
is in one of the
general registers.

jump-unconditionally

`junc Ra`

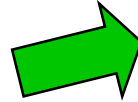

Jump to address in Ra.

Jump instructions

The address
to be jumped to
is in one of the
general registers.

jump-to-subroutine



```
jsub Ra Rb
```

Jump to address in Ra.

The next location after
the current one is put
in Rb.

Control Sequencer FSM

- Inputs are bits from instruction being interpreted
- Outputs are strobes to various registers, 3-state devices, etc.

Control Sequence

- There is a sequence common to all instructions in which the instruction is fetched from memory,

followed by

- A sequence particular to the type of instruction being executed.

ISC Instruction Fetch

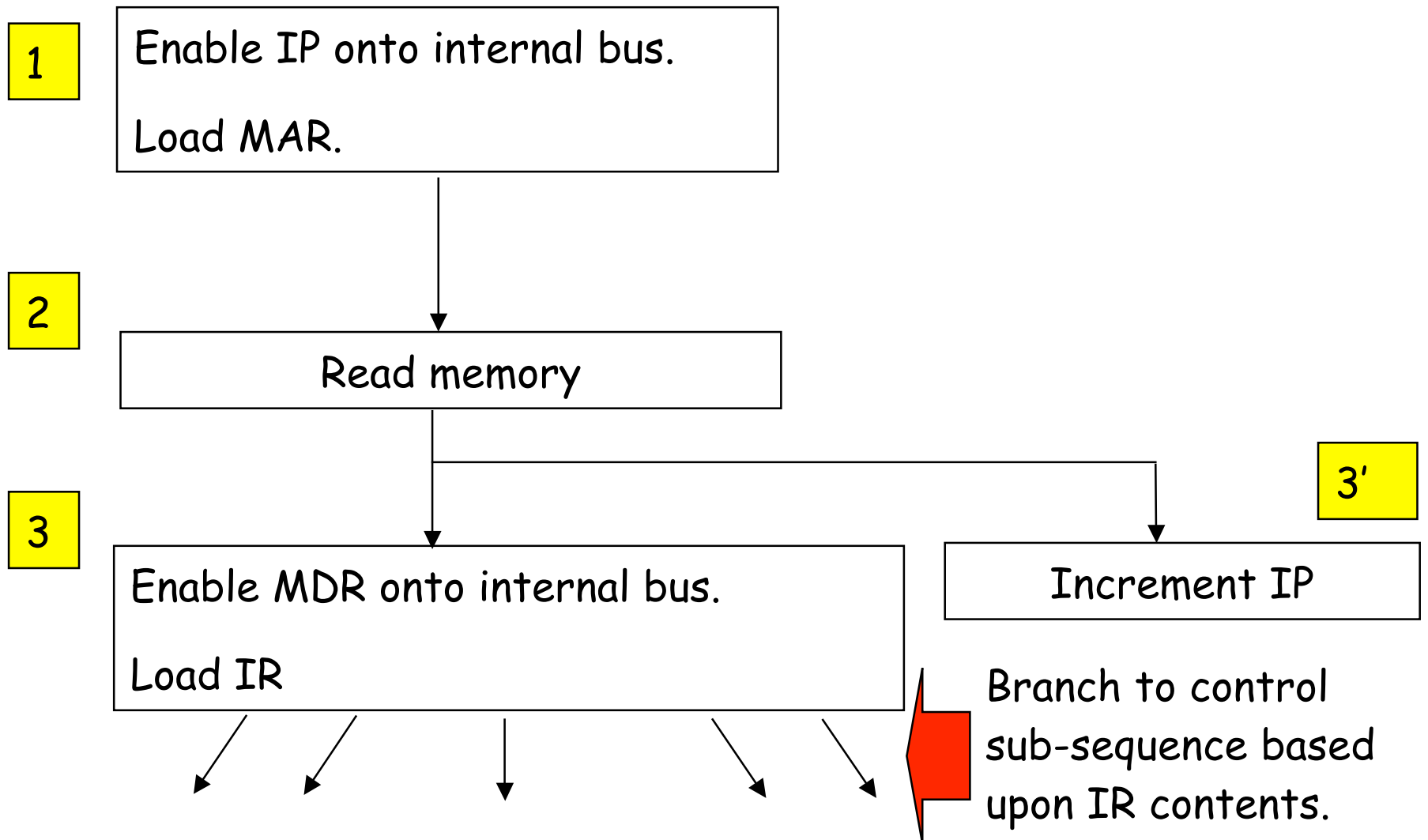

1

Enable IP onto internal bus.
Load MAR.

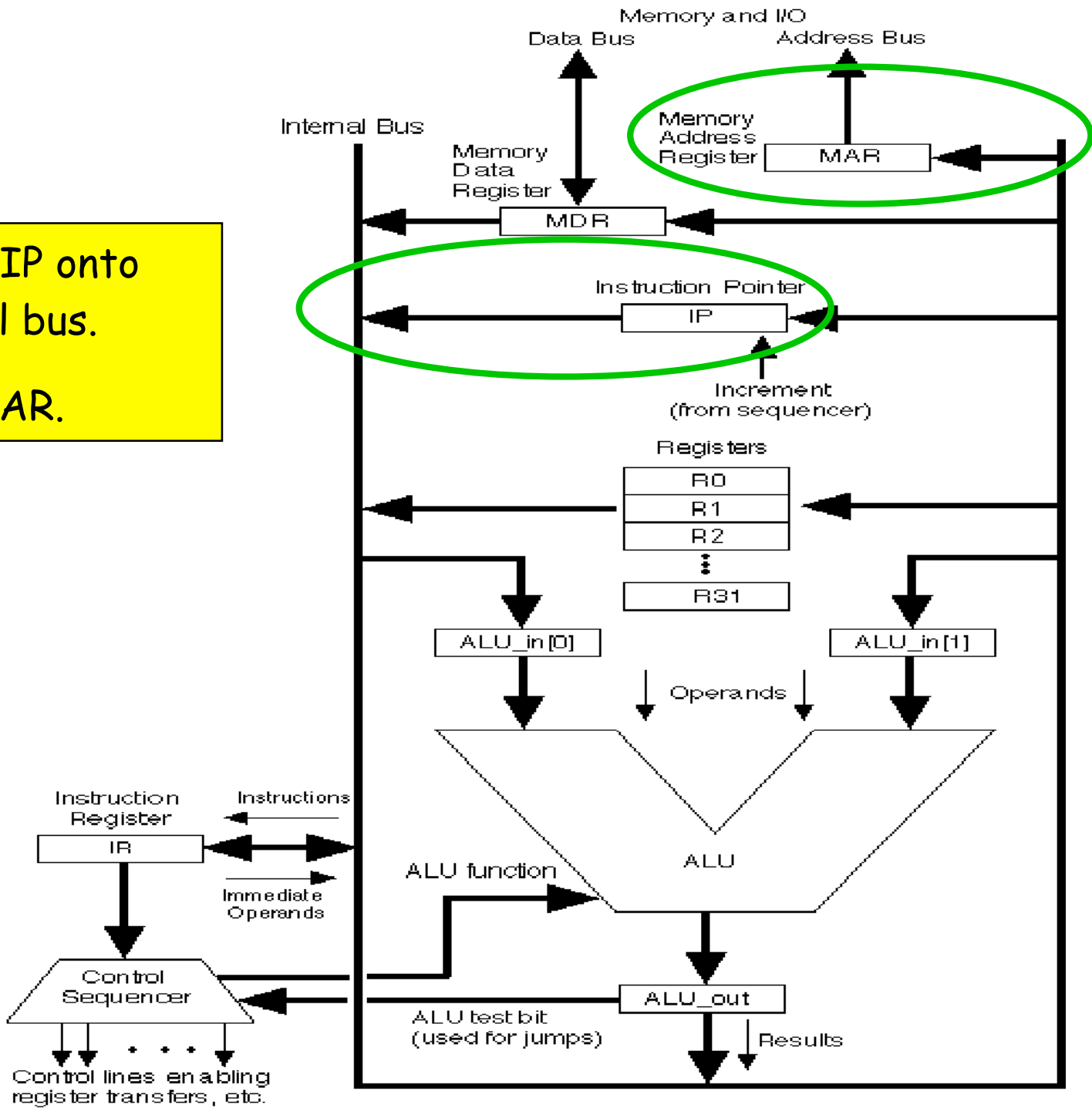

2

Read memory

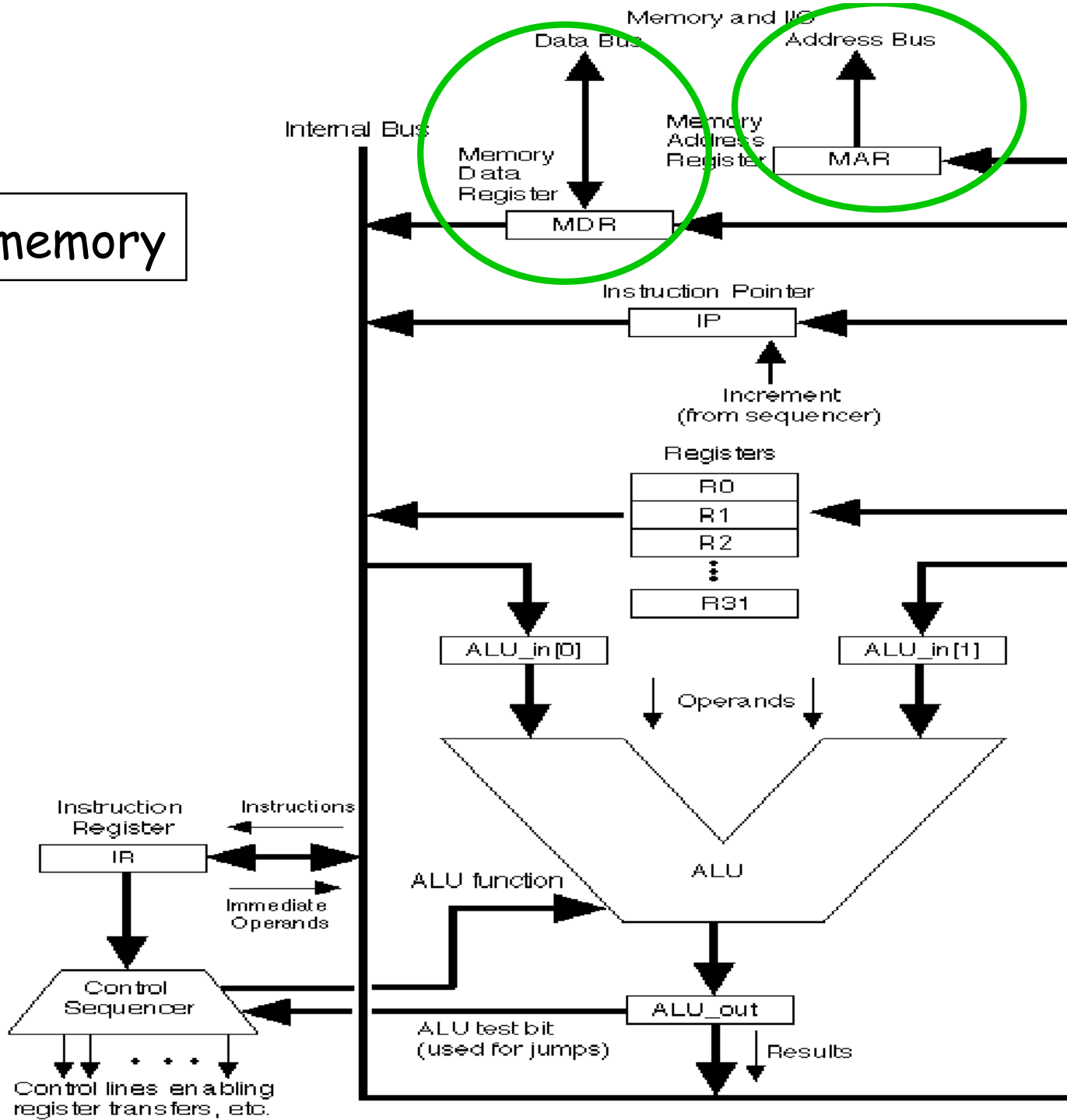

3

Enable MDR onto internal bus.
Load IR

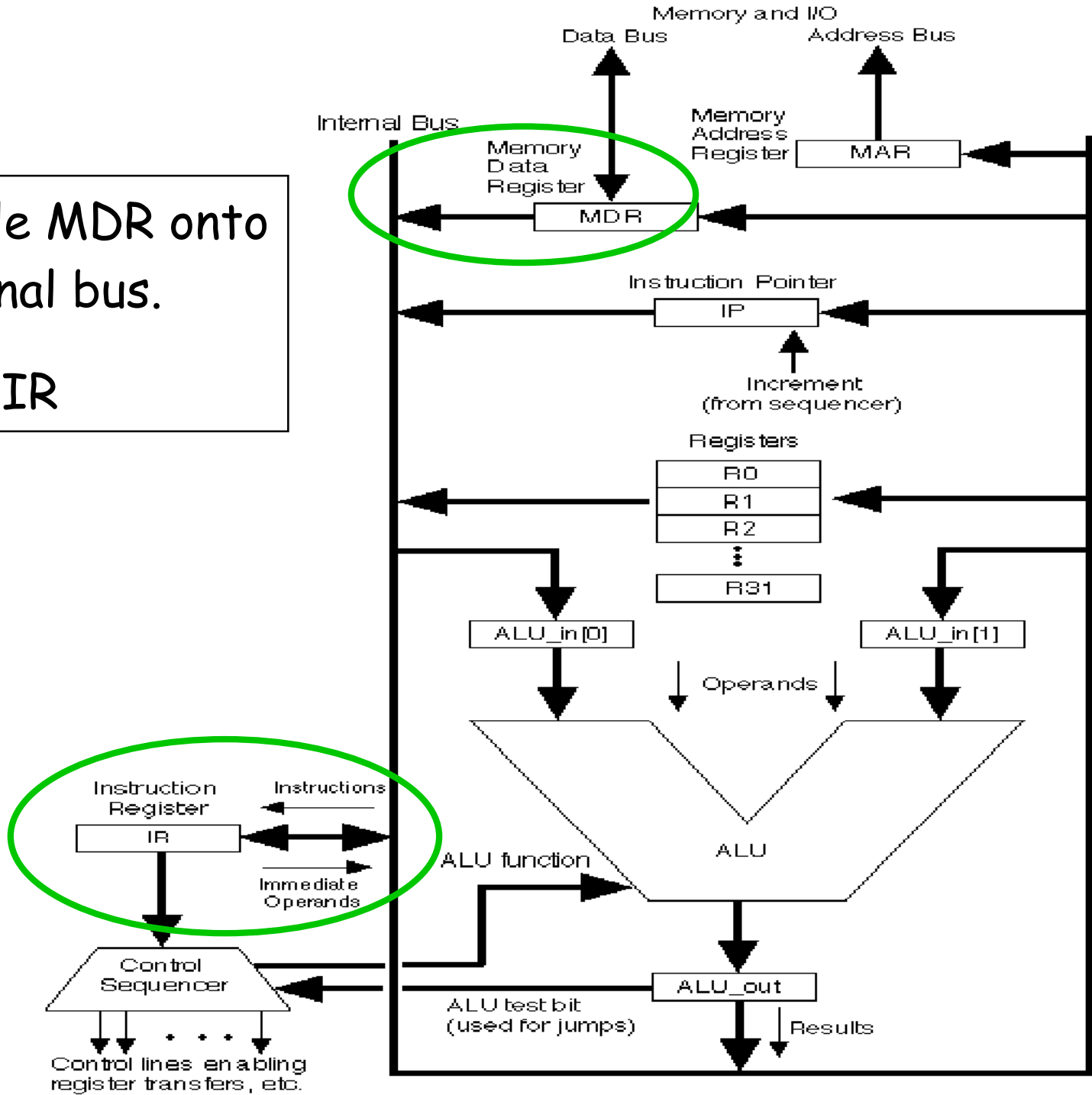

3'

Increment IP

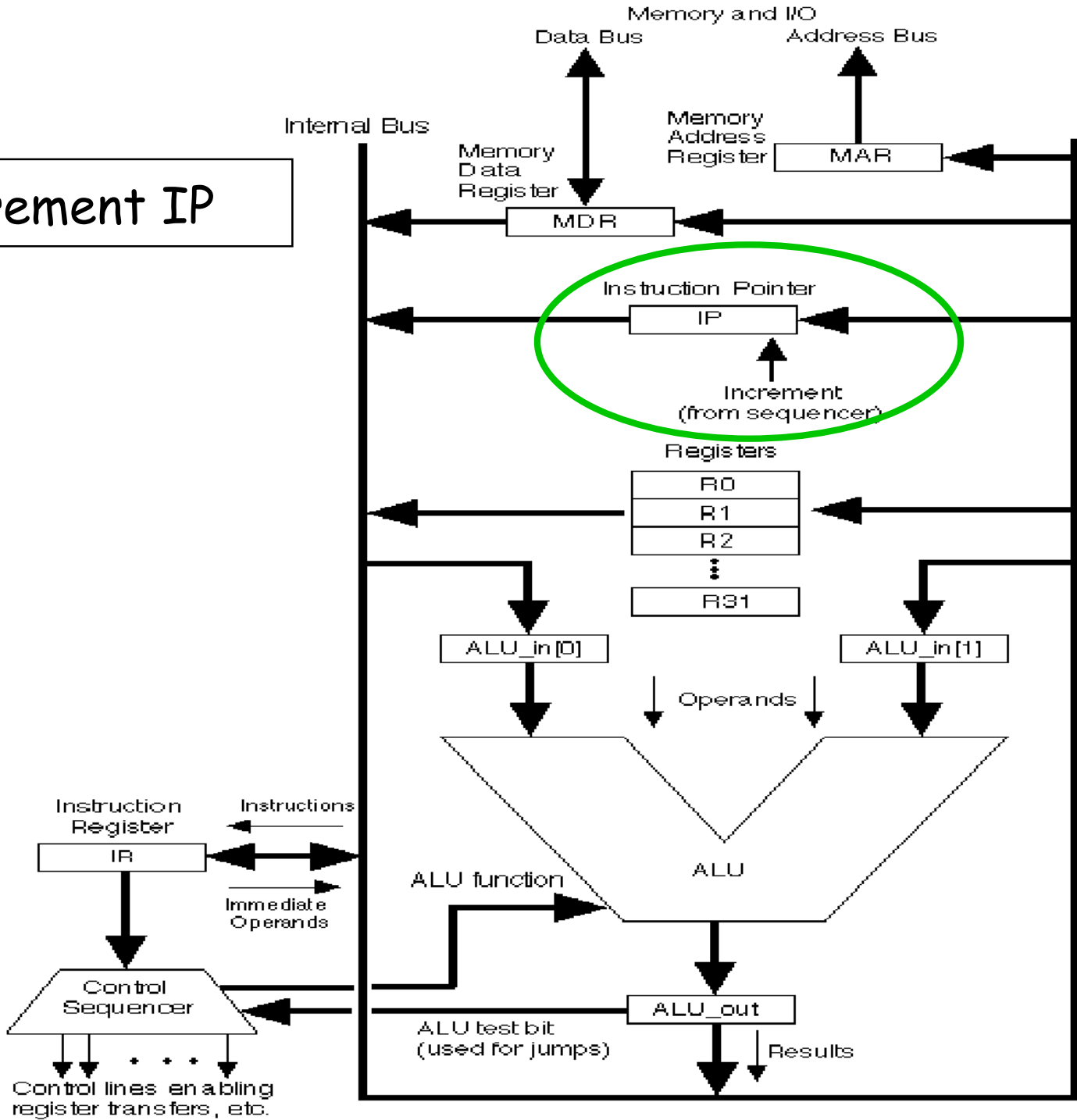

Control Subsequence Example: Add Ra Rb Rc

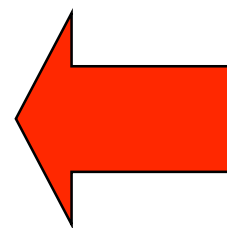
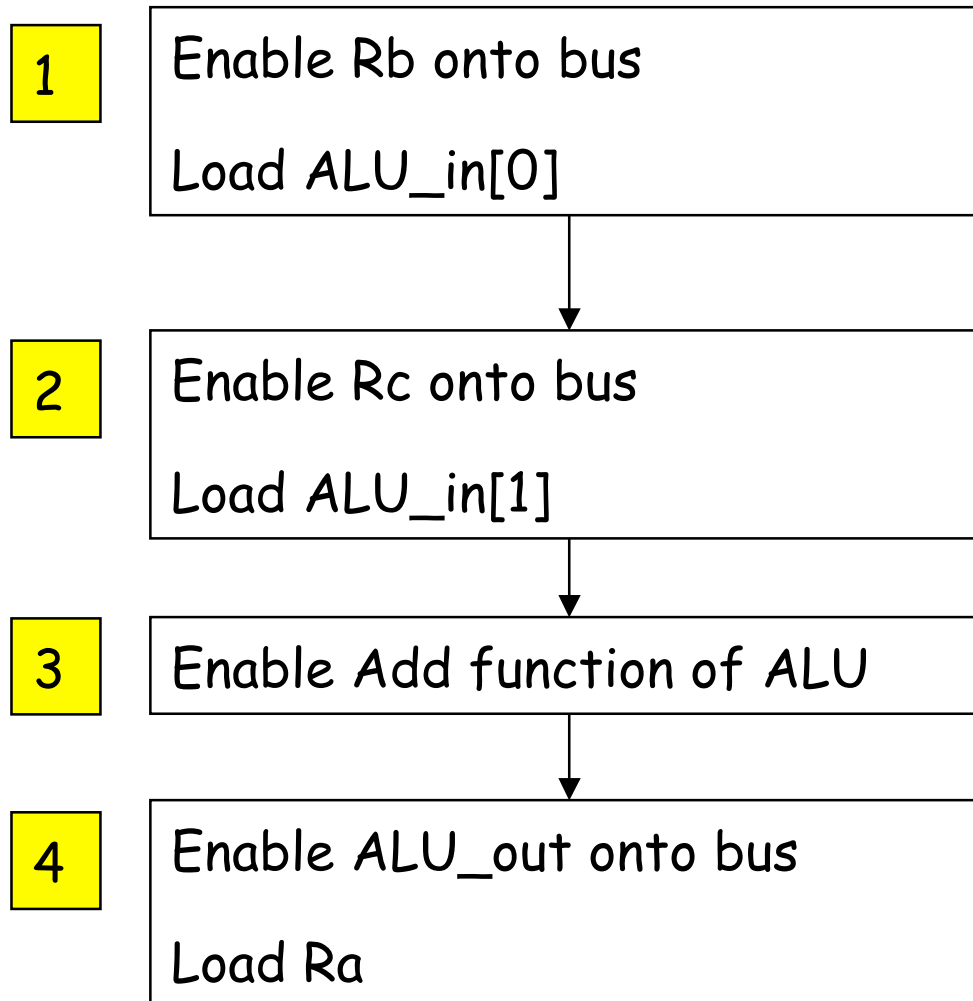

Actual addition
takes place in
between.

1

Enable Rb onto bus

Load ALU_in[0]

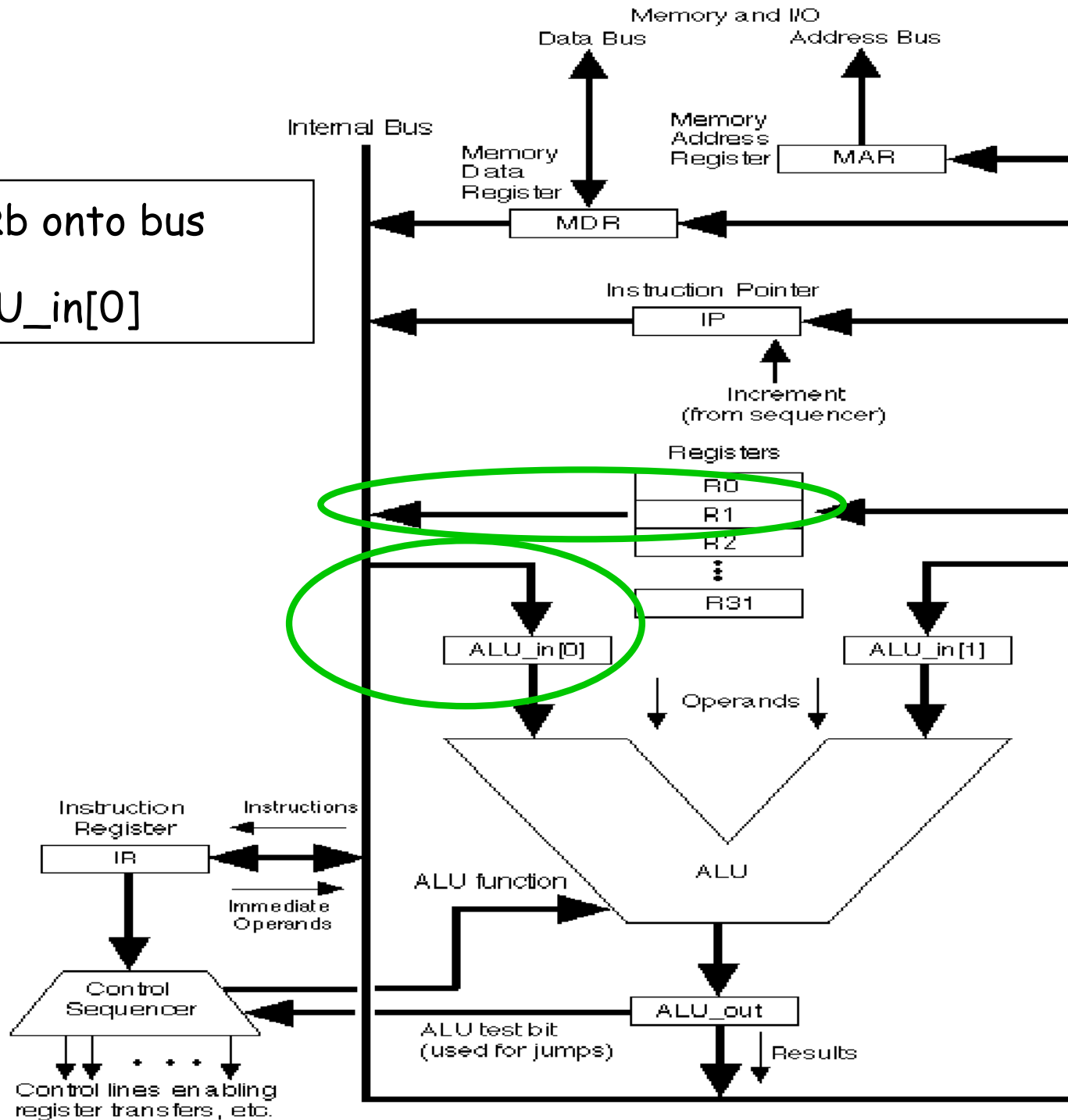

2

Enable Rc onto bus
Load ALU_in[1]

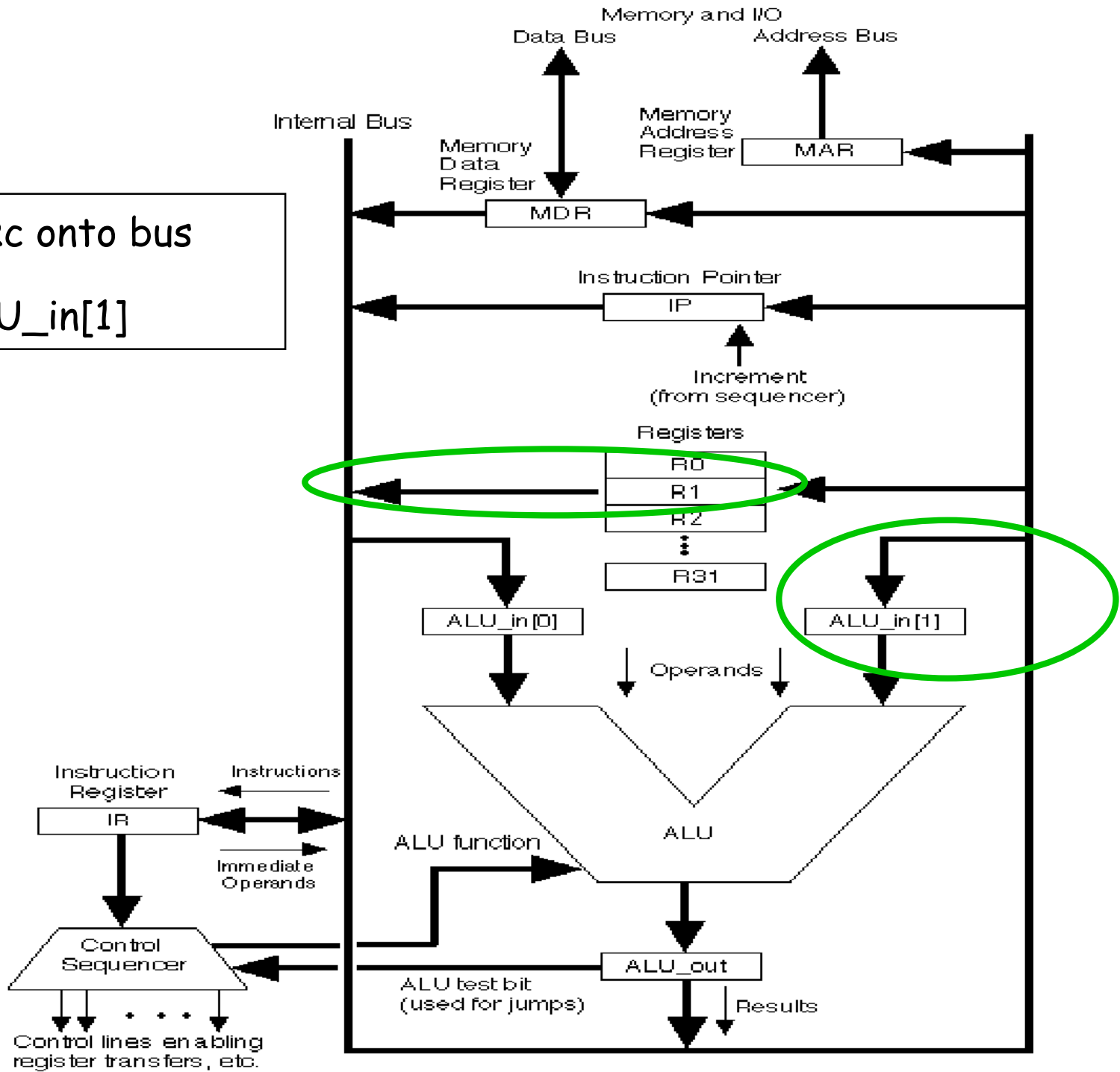

3

Enable Add function of ALU

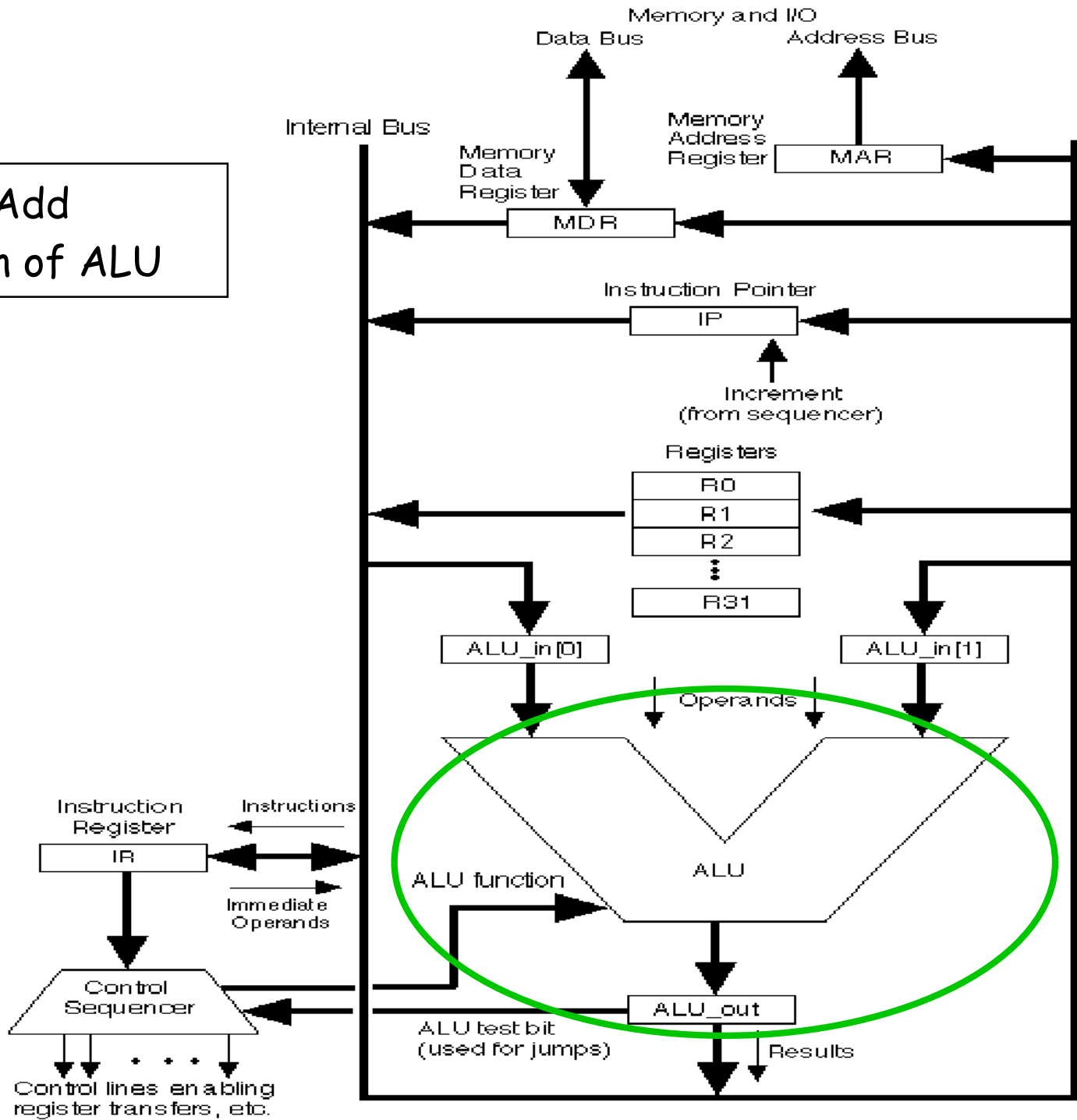

4

Enable ALU_out
onto bus
Load Ra

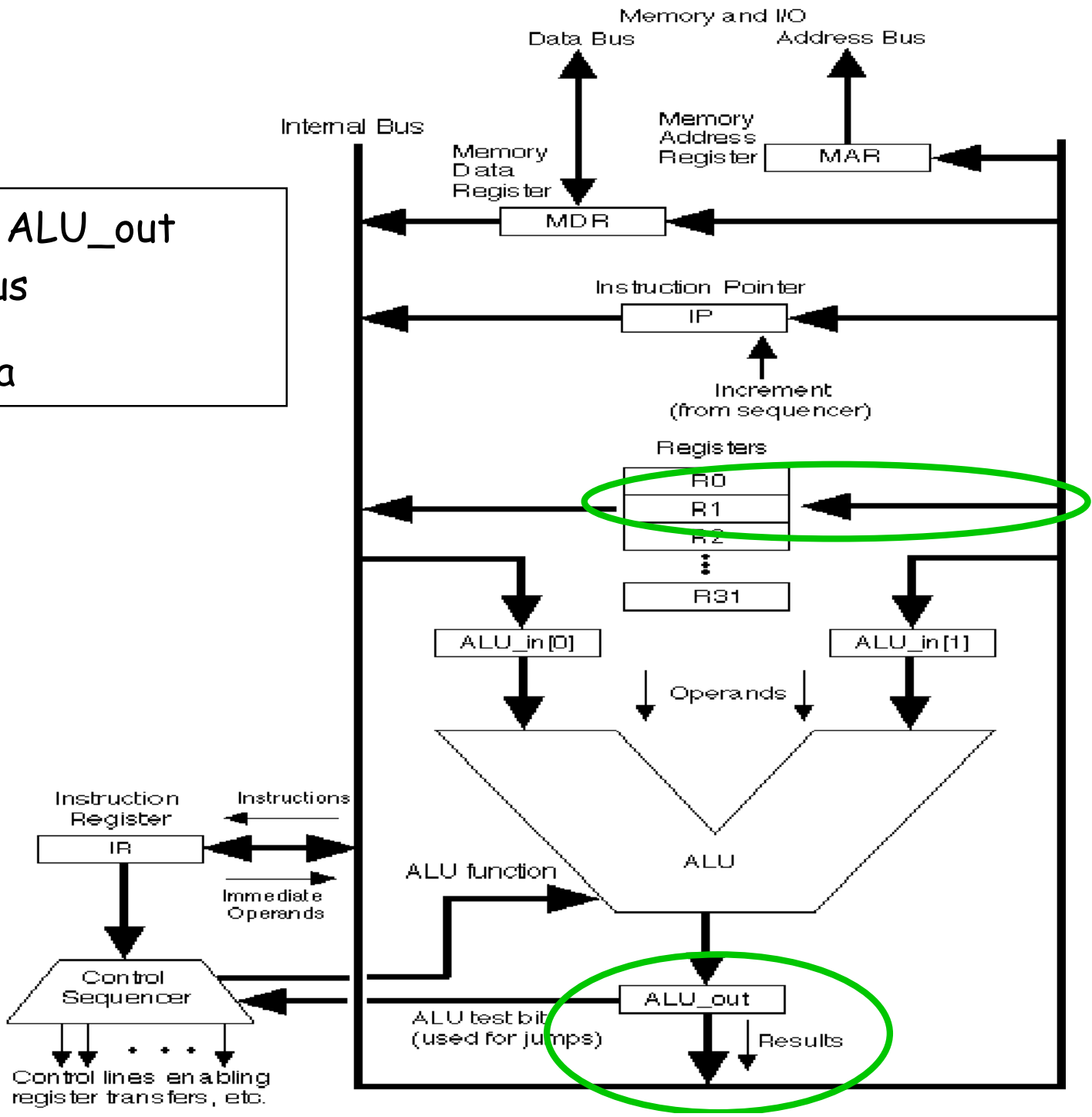

Exercise

- What would the instruction subsequences be for:
 - aim (add immediate)
 - load
 - store
 - jeq (jump-if-equal)

Machine-Level Programming

- Programming of the bare machine is typically done in "assembly language"
- One line of assembly language is roughly equal to one machine instruction
- A program, the "assembler", allows use of symbolic identifiers for addresses.

Programming in Assembly Language

- Programming in assembly language reminds me of the Japanese saying about climbing Mt. Fuji:

“To never have climbed Mt. Fuji is to be a fool.
Only a (bigger) fool would climb
Mt. Fuji more than once.”

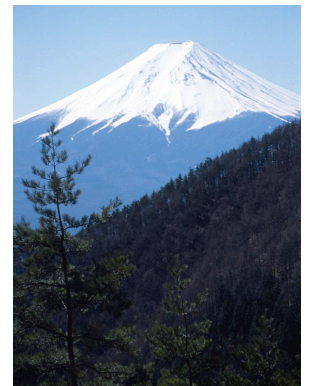

ISCAL

ISC Assembly Language

- See <http://www.cs.hmc.edu/~keller/isc/>
- Free-form input, but generally format line-by-line
- Regular instructions
 - *Ra, Rb, Rc* are register names
 - *C* is a constant
 - **lim** *Ra C*
 - **add** *Ra Rb Rc*
 - **copy** *Ra Rb*
 - **shl** *Ra Rb*
 - **load** *Ra Rb*
 - etc.

ISCAL

- Assembler directives: not instructions to computer, but rather tell assembler what to do:
 - **define** *Identifier Value* Defines *Identifier* to have *Value*.
 - **use** *Identifier* Defines *Identifier* to name an unused register.
 - **origin** *Value* Begin loading instructions at specified memory location. The location counter is incremented as loading progresses.
 - **label** *Identifier* Associates current instruction location with *Identifier*.

ISCAL code for summing an array

```
use array use count // array base and count
use sum use zero use value // local registers
use loop use done // address registers
```

... insert code to load array and count values ...

```
lim sum 0 // initialize sum
lim zero 0 // comparison value
lim done done_loc // address of instruction following
lim loop loop_loc // address of next instruction
```

label loop_loc

```
jlte done count zero // jump if <= 0
load value array // load register next array value
add sum value sum // add the next number to the sum
aim array 1 // add 1 to the array address
aim count -1 // add -1 to the count
junc loop // go back and compare
```

label done_loc

Array Summation

In Processor

General Registers

array

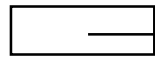

count

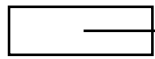

sum

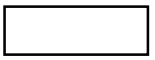

zero

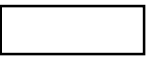

value

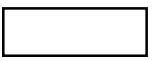

loop

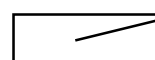

done

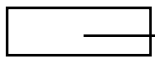

IP

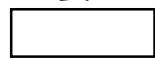

In Memory

Array to be summed

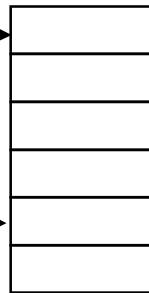

Program code (symbolic,
the actual code is a bit vector)

loop_loc

jlte done count zero
load value array
add sum value sum
aim array 1
aim count -1
junc loop

done_loc

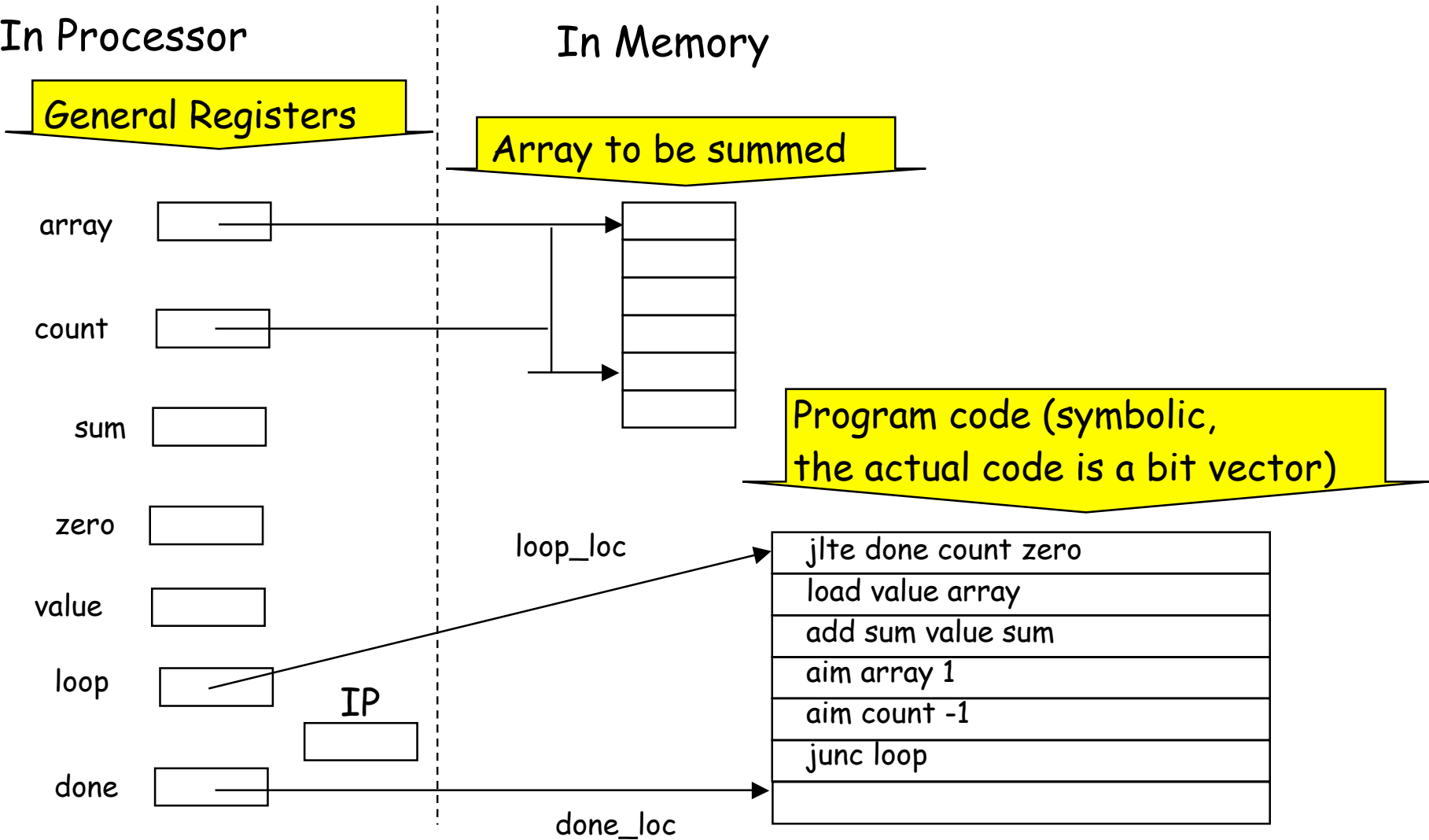

Array Summation

In Processor

General Registers

array

count 5

sum 0

zero 0

value

loop

done

In Memory

Array to be summed

5

3

6

2

9

Program code (symbolic,
the actual code is a bit vector)

loop_loc

jlte done count zero

load value array

add sum value sum

aim array 1

aim count -1

junc loop

done_loc

IP

Array Summation

In Processor

General Registers

array

count 5

sum 0

zero 0

value 5

loop

done

In Memory

Array to be summed

5
3
6
2
9

Showing register state after instruction is executed.

Program code (symbolic, the actual code is a bit vector)

loop_loc

jltz done count zero
load value array
add sum value sum
aim array 1
aim count -1
junc loop

done_loc

IP

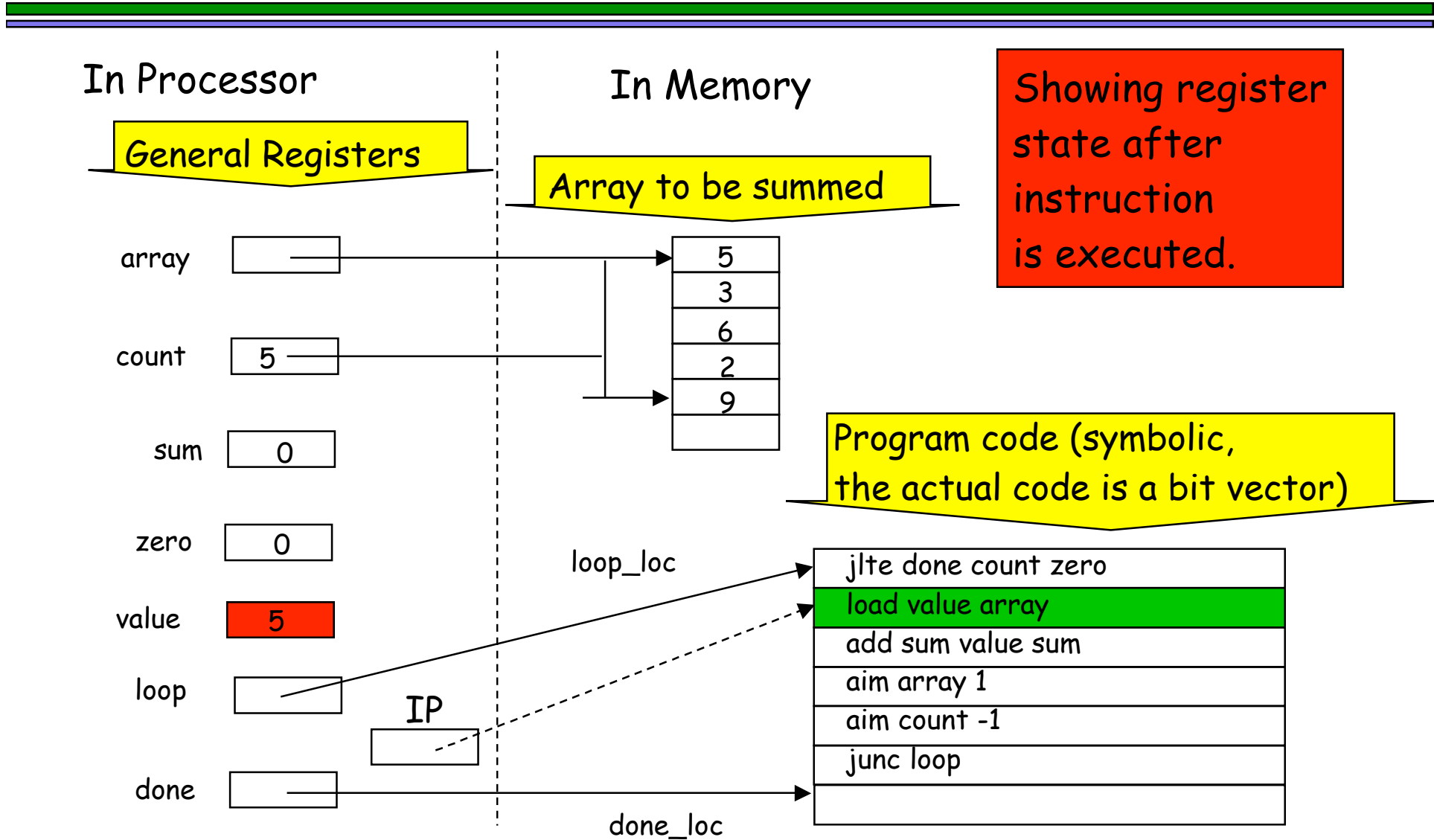

Array Summation

In Processor

General Registers

array

count 5

sum 5

zero 0

value 5

loop

done

In Memory

Array to be summed

5
3
6
2
9

Showing register state after instruction is executed.

Program code (symbolic, the actual code is a bit vector)

loop_loc

jlte done count zero
load value array
add sum value sum
aim array 1
aim count -1
junc loop

IP

done_loc

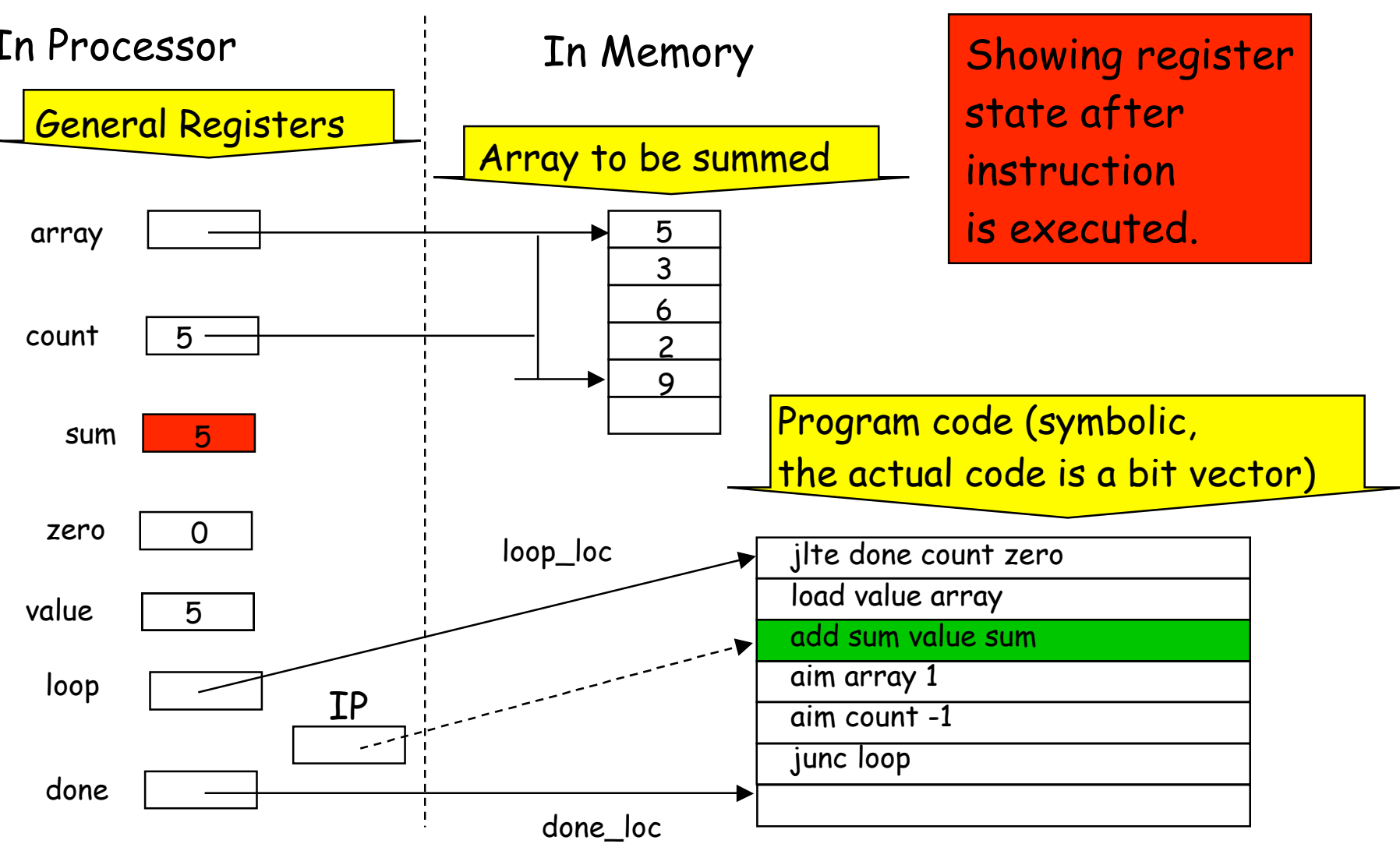

Array Summation

In Processor

General Registers

array

count 5

sum 5

zero 0

value 5

loop

done

IP

In Memory

Array to be summed

5
3
6
2
9

Showing register state after instruction is executed.

Program code (symbolic, the actual code is a bit vector)

loop_loc

jlte done count zero
load value array
add sum value sum
aim array 1
aim count -1
junc loop

done_loc

Array Summation

In Processor

General Registers

array

count 4

sum 5

zero 0

value 5

loop

done

IP

In Memory

Array to be summed

5
3
6
2
9

Showing register state after instruction is executed.

Program code (symbolic, the actual code is a bit vector)

loop_loc

jlte done count zero
load value array
add sum value sum
aim array 1
aim count -1
junc loop

done_loc

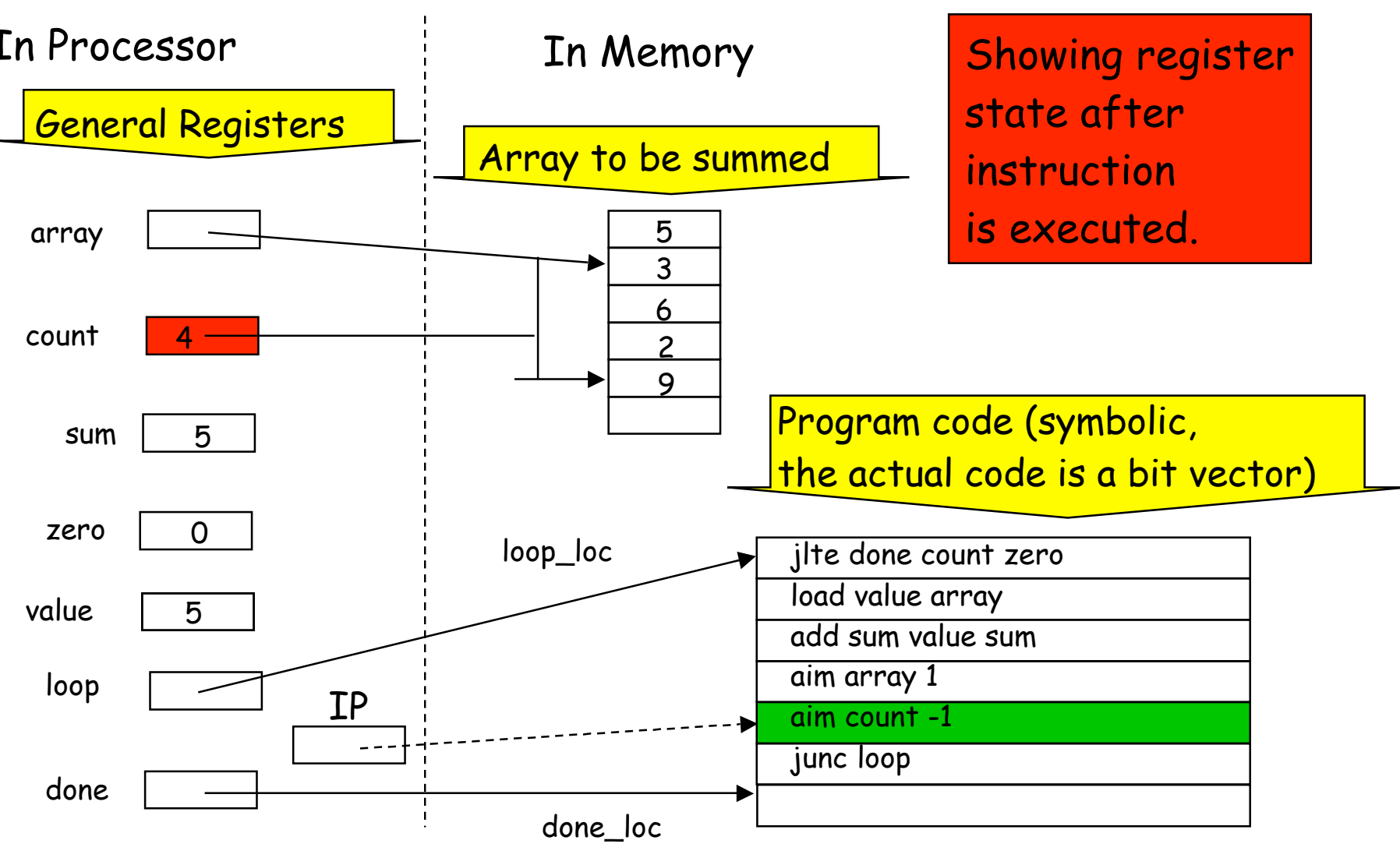

Array Summation

In Processor

General Registers

array

count 4

sum 5

zero 0

value 5

loop

done

IP

In Memory

Array to be summed

5
3
6
2
9

Showing register state after instruction is executed.

Program code (symbolic, the actual code is a bit vector)

loop_loc

jltc done count zero
load value array
add sum value sum
aim array 1
aim count -1
junc loop

done_loc

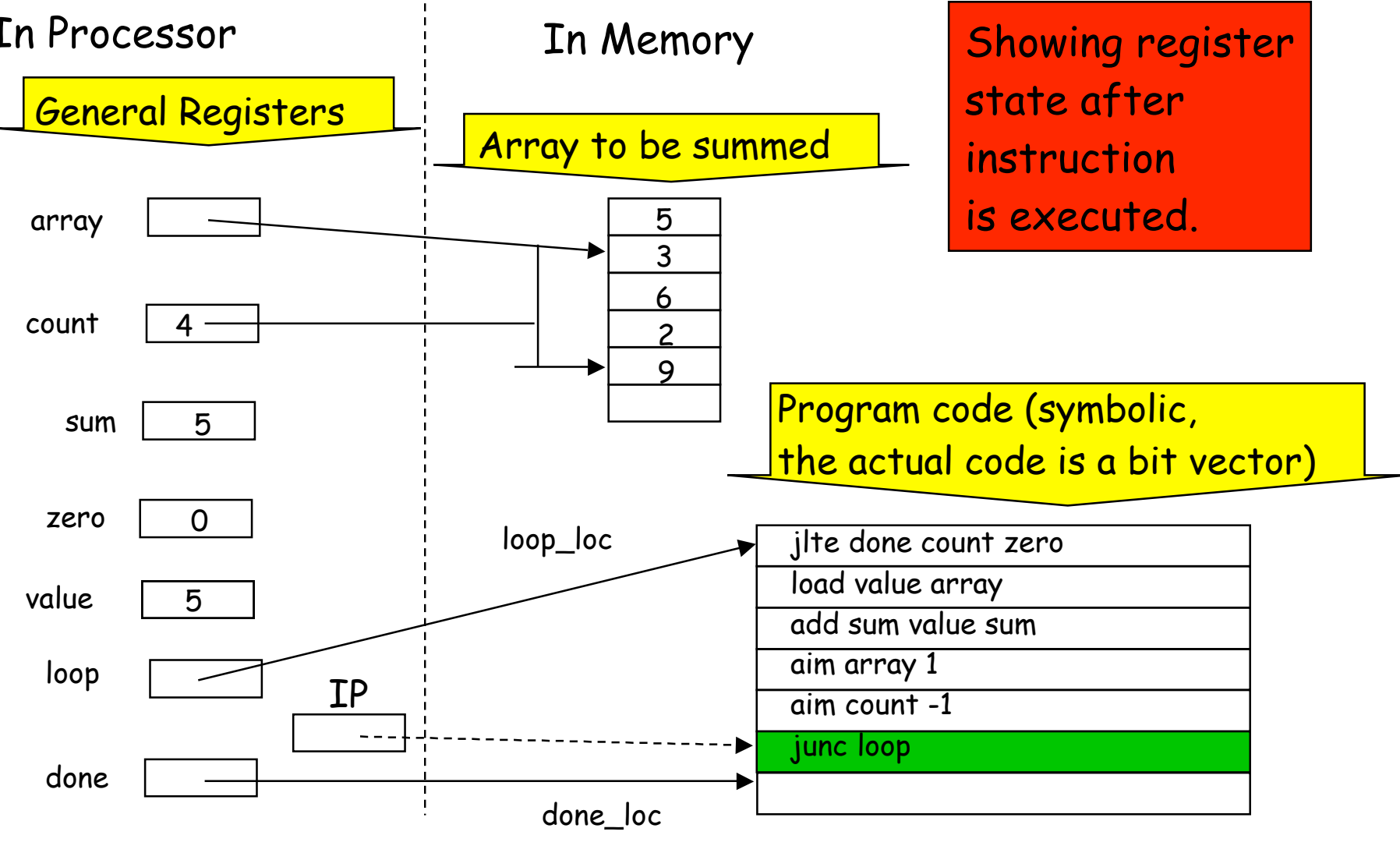

Array Summation

In Processor

General Registers

array

count 4

sum 5

zero 0

value 5

loop

done

In Memory

Array to be summed

5
3
6
2
9

Program code (symbolic,
the actual code is a bit vector)

loop_loc

jlte done count zero

load value array

add sum value sum

aim array 1

aim count -1

junc loop

IP

done_loc

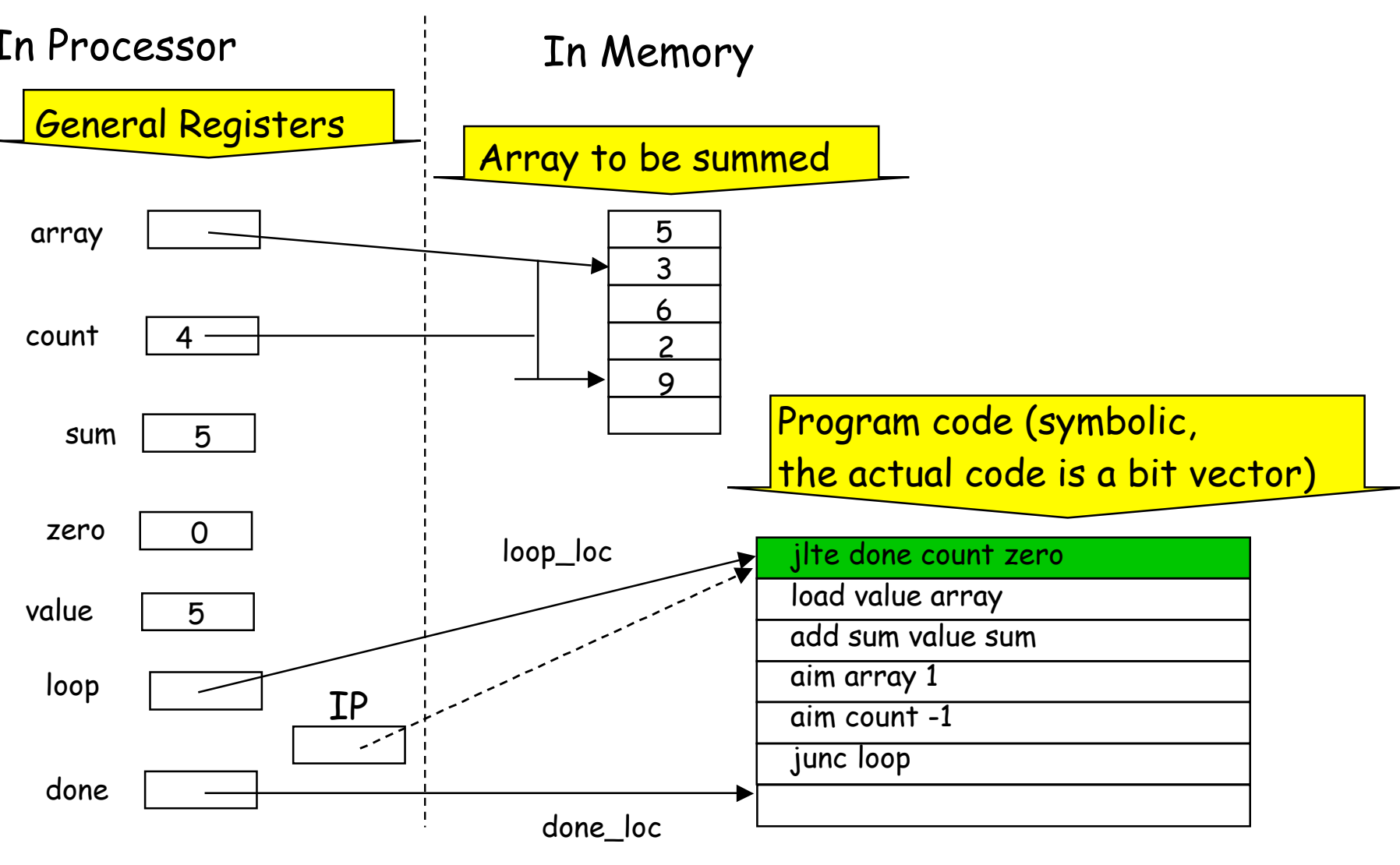

Array Summation

In Processor

General Registers

array

count 4

sum 5

zero 0

value 3

loop

done

In Memory

Array to be summed

5
3
6
2
9

Showing register state after instruction is executed.

Program code (symbolic, the actual code is a bit vector)

loop_loc

jlte done count zero
load value array
add sum value sum
aim array 1
aim count -1
junc loop

IP

done_loc

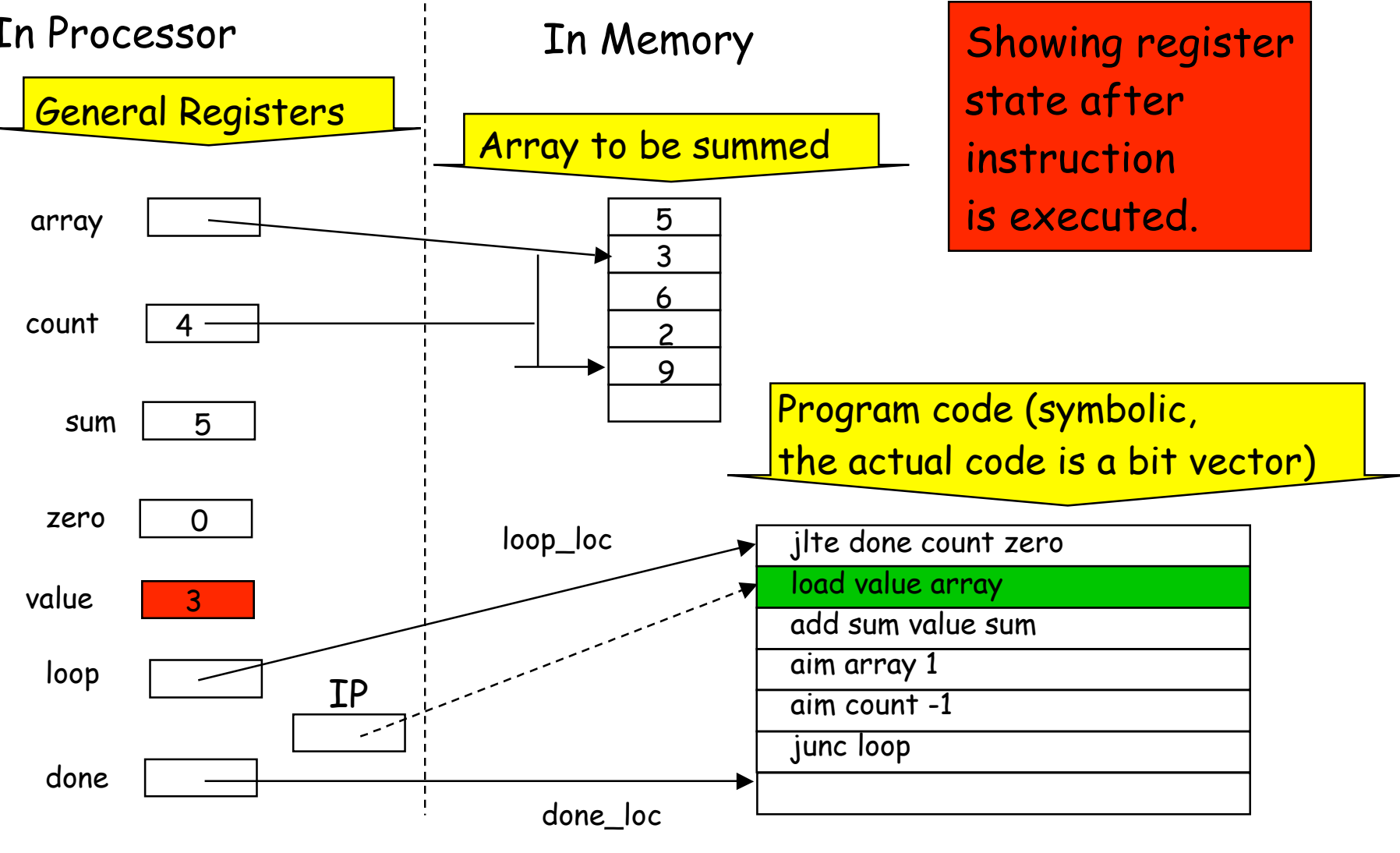

Array Summation

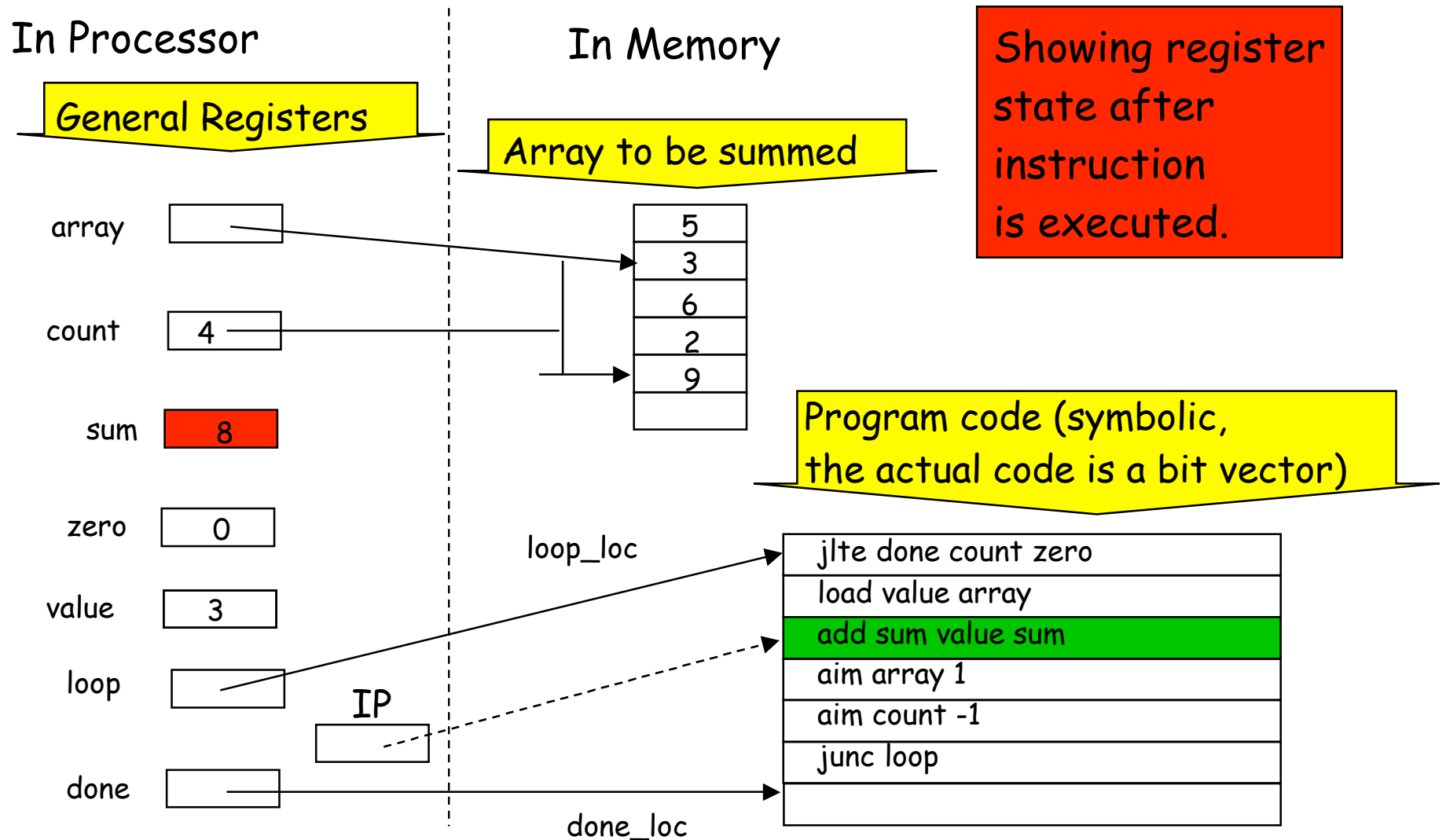

Array Summation

In Processor

General Registers

array

count 4

sum 8

zero 0

value 3

loop

done

IP

In Memory

Array to be summed

5
3
6
2
9

Showing register state after instruction is executed.

Program code (symbolic, the actual code is a bit vector)

loop_loc

jlte done count zero
load value array
add sum value sum
aim array 1
aim count -1
junc loop

done_loc

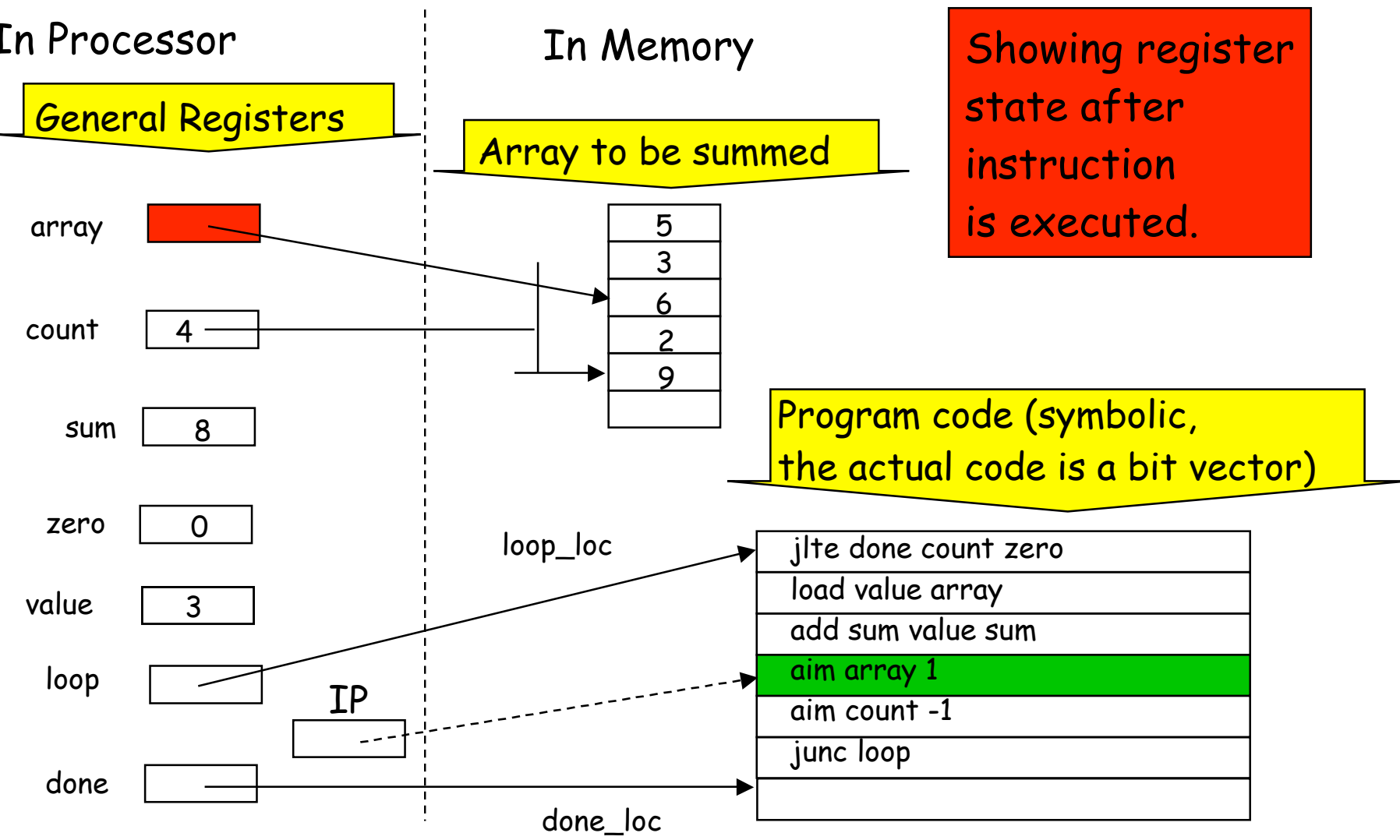

Array Summation

In Processor

General Registers

array

count 3

sum 8

zero 0

value 3

loop

done

IP

In Memory

Array to be summed

5
3
6
2
9

Showing register state after instruction is executed.

Program code (symbolic, the actual code is a bit vector)

loop_loc

jlte done count zero
load value array
add sum value sum
aim array 1
aim count -1
junc loop

done_loc

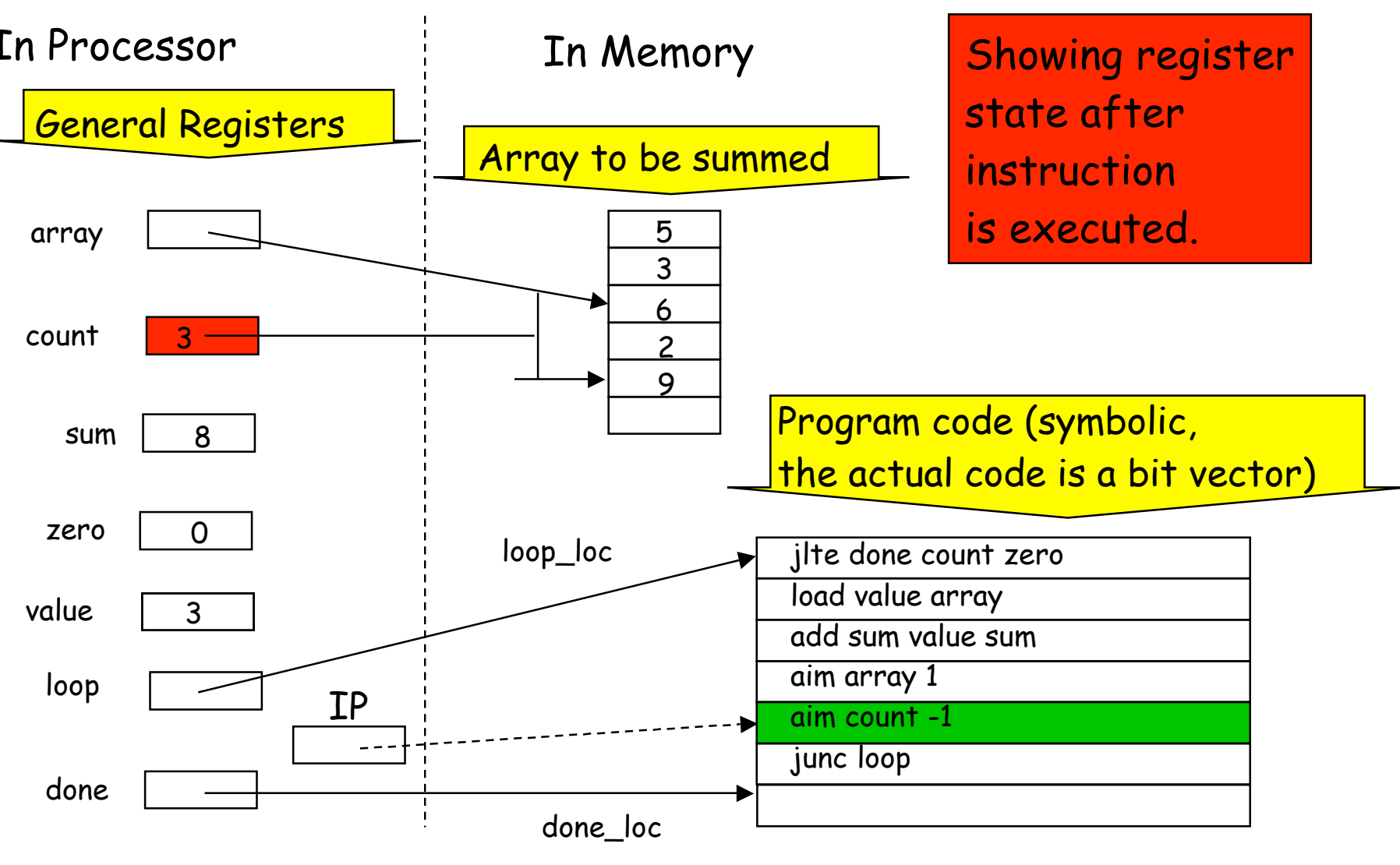

Array Summation

In Processor

General Registers

array

count 3

sum 8

zero 0

value 3

loop

done

IP

In Memory

Array to be summed

5
3
6
2
9

Showing register state after instruction is executed.

Program code (symbolic, the actual code is a bit vector)

loop_loc

jlte done count zero
load value array
add sum value sum
aim array 1
aim count -1
junc loop

done_loc

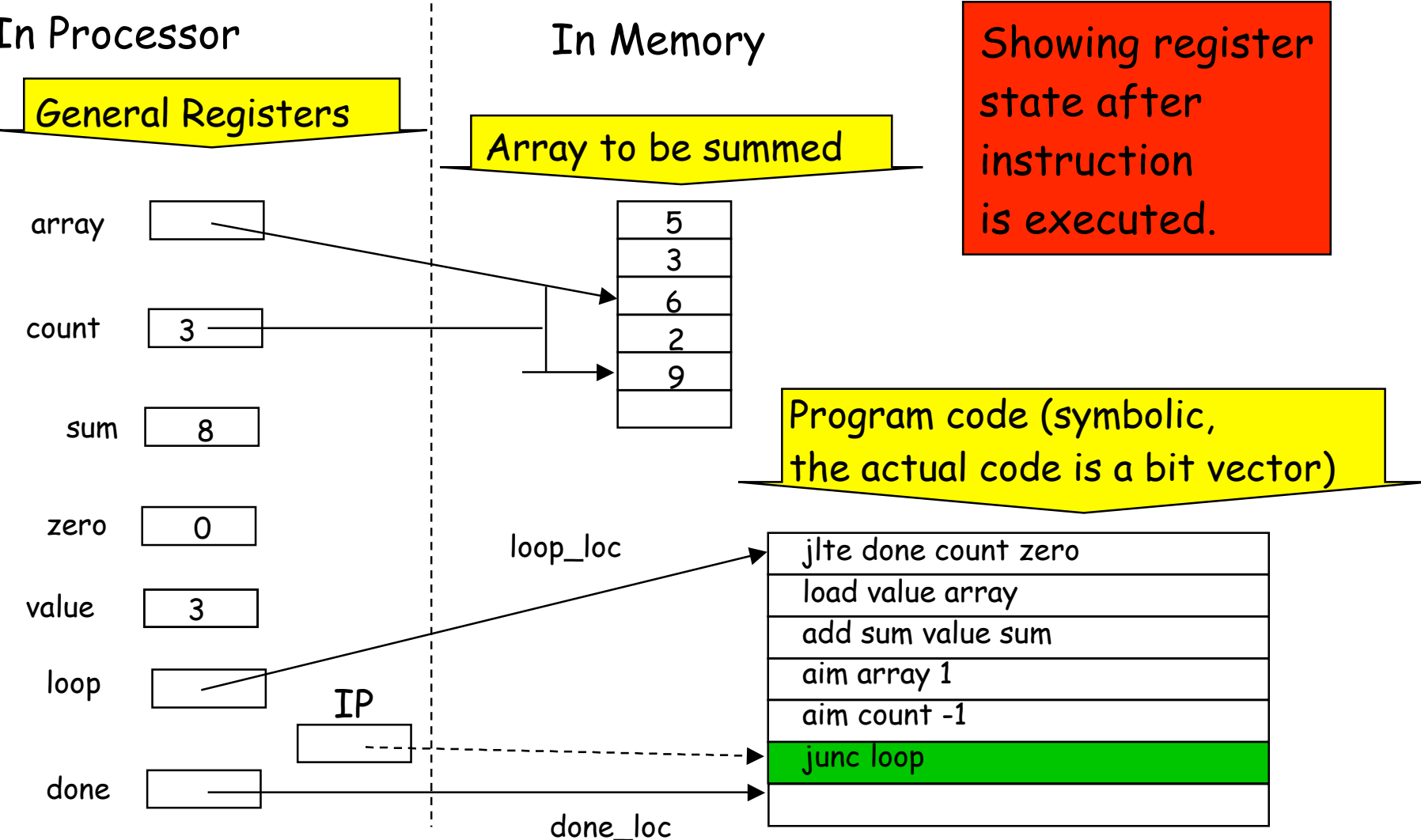

Array Summation

In Processor

General Registers

array

count 3

sum 8

zero 0

value 3

loop

done

In Memory

Array to be summed

5
3
6
2
9

Program code (symbolic,
the actual code is a bit vector)

loop_loc

jlte done count zero

load value array

add sum value sum

aim array 1

aim count -1

junc loop

IP

done_loc

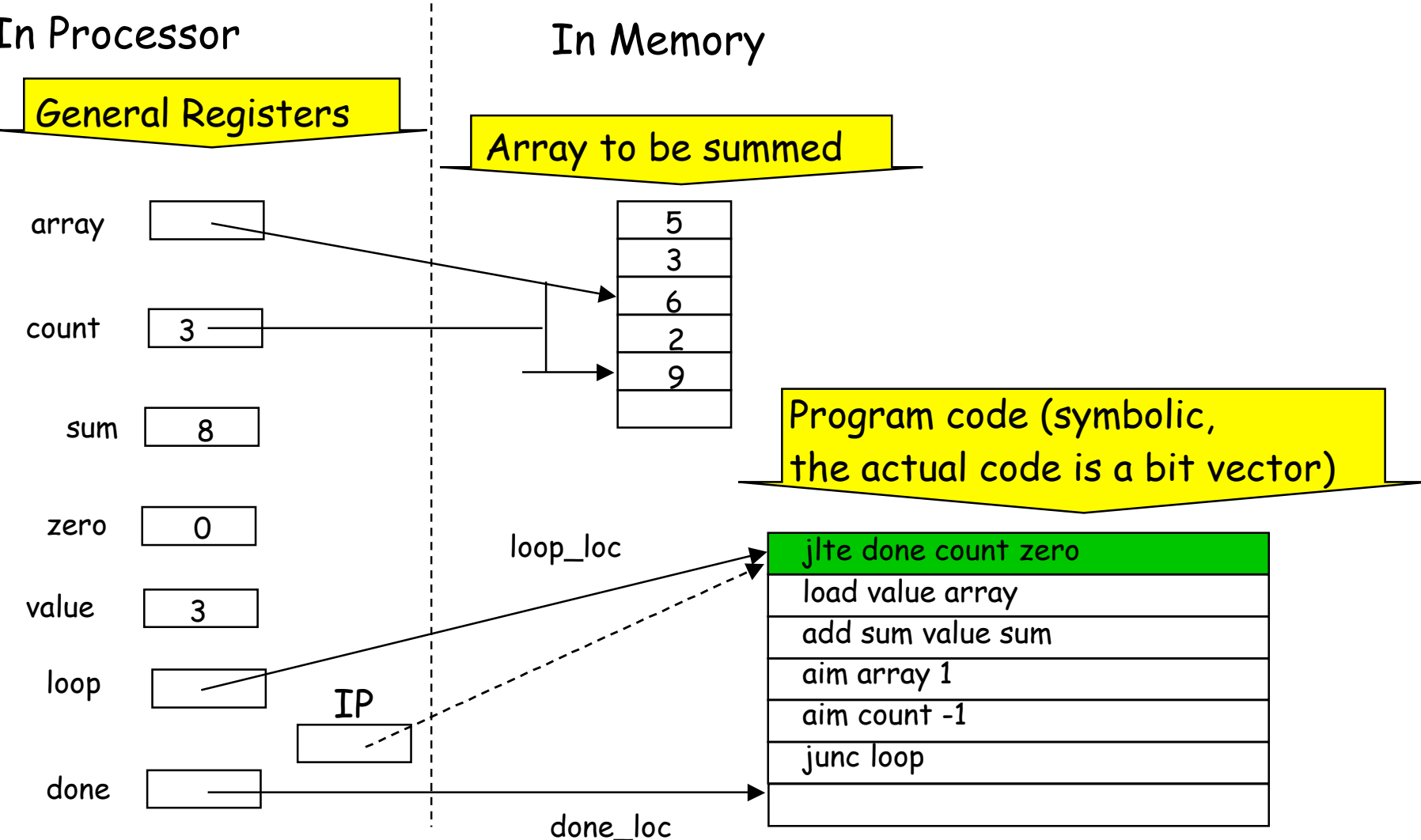

Array Summation

In Processor

General Registers

array

count 3

sum 8

zero 0

value 6

loop

done

In Memory

Array to be summed

5
3
6
2
9

Showing register state after instruction is executed.

Program code (symbolic, the actual code is a bit vector)

loop_loc

jlte done count zero
load value array
add sum value sum
aim array 1
aim count -1
junc loop

IP

done_loc

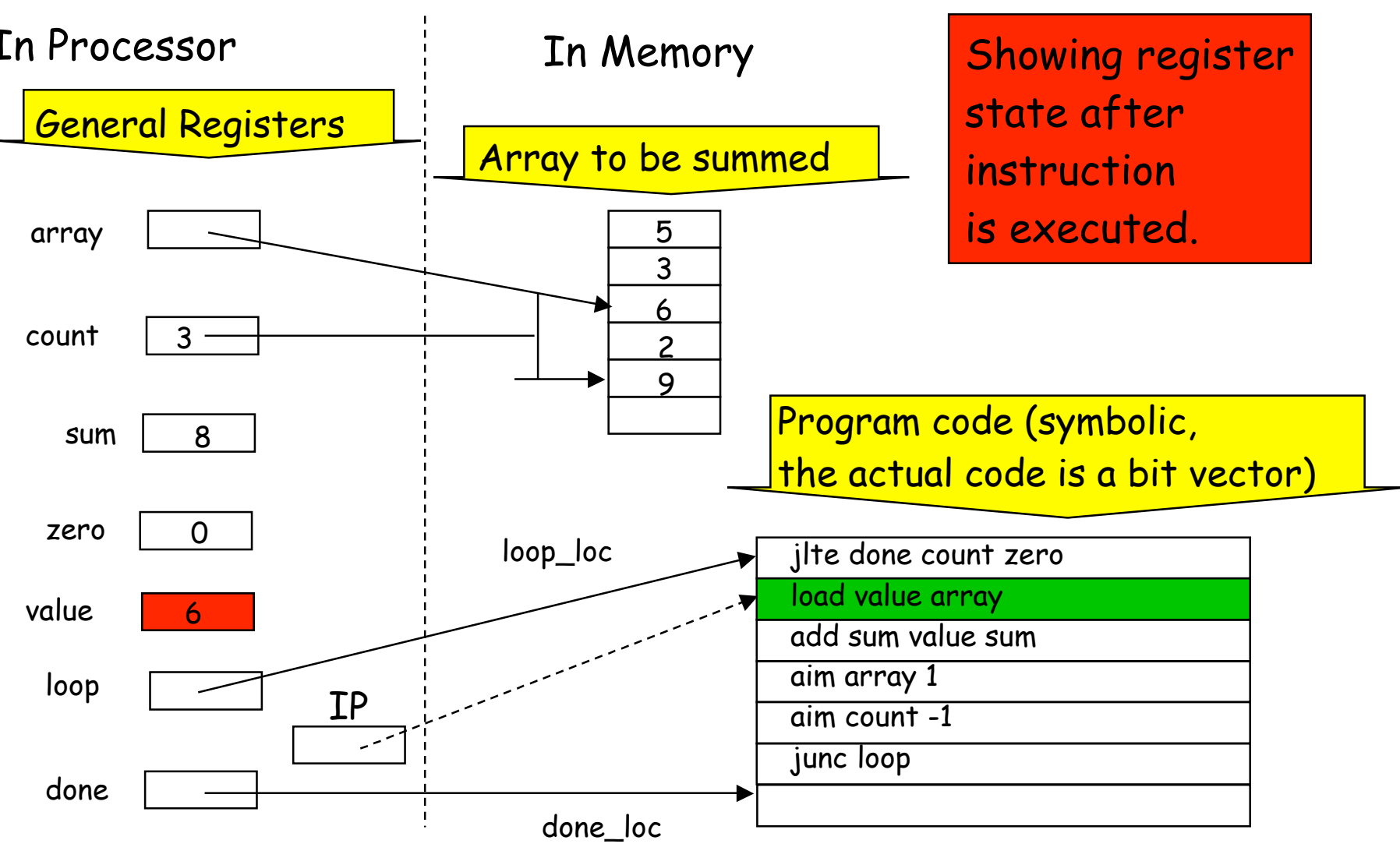

Array Summation

In Processor

General Registers

array

count 3

sum 14

zero 0

value 6

loop

done

IP

In Memory

Array to be summed

5
3
6
2
9

Showing register state after instruction is executed.

Program code (symbolic, the actual code is a bit vector)

loop_loc

jlte done count zero
load value array
add sum value sum
aim array 1
aim count -1
junc loop

done_loc

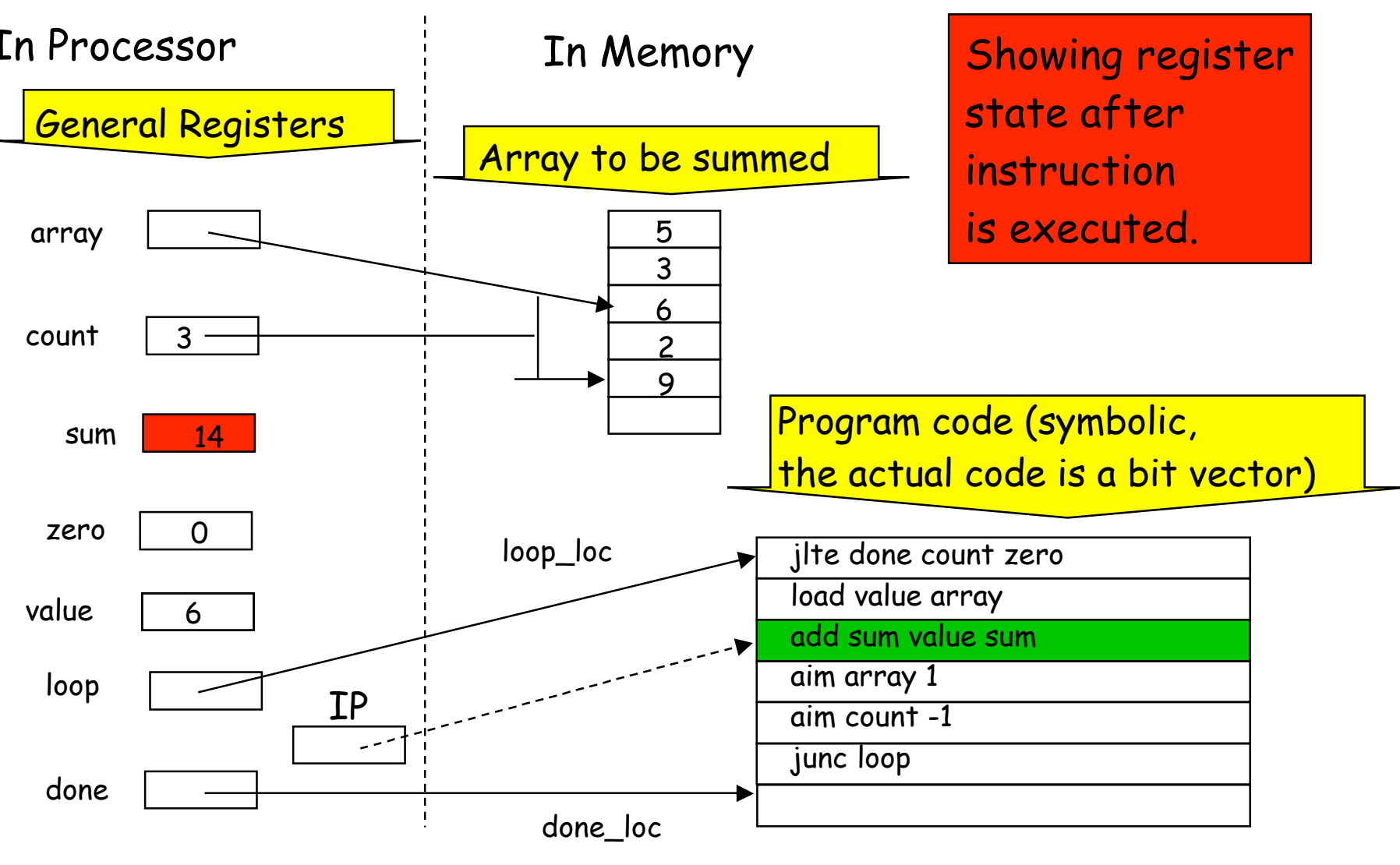

Array Summation

In Processor

General Registers

array

count 3

sum 14

zero 0

value 6

loop

done

IP

In Memory

Array to be summed

5
3
6
2
9

Showing register state after instruction is executed.

Program code (symbolic, the actual code is a bit vector)

loop_loc

jlte done count zero
load value array
add sum value sum
aim array 1
aim count -1
junc loop

done_loc

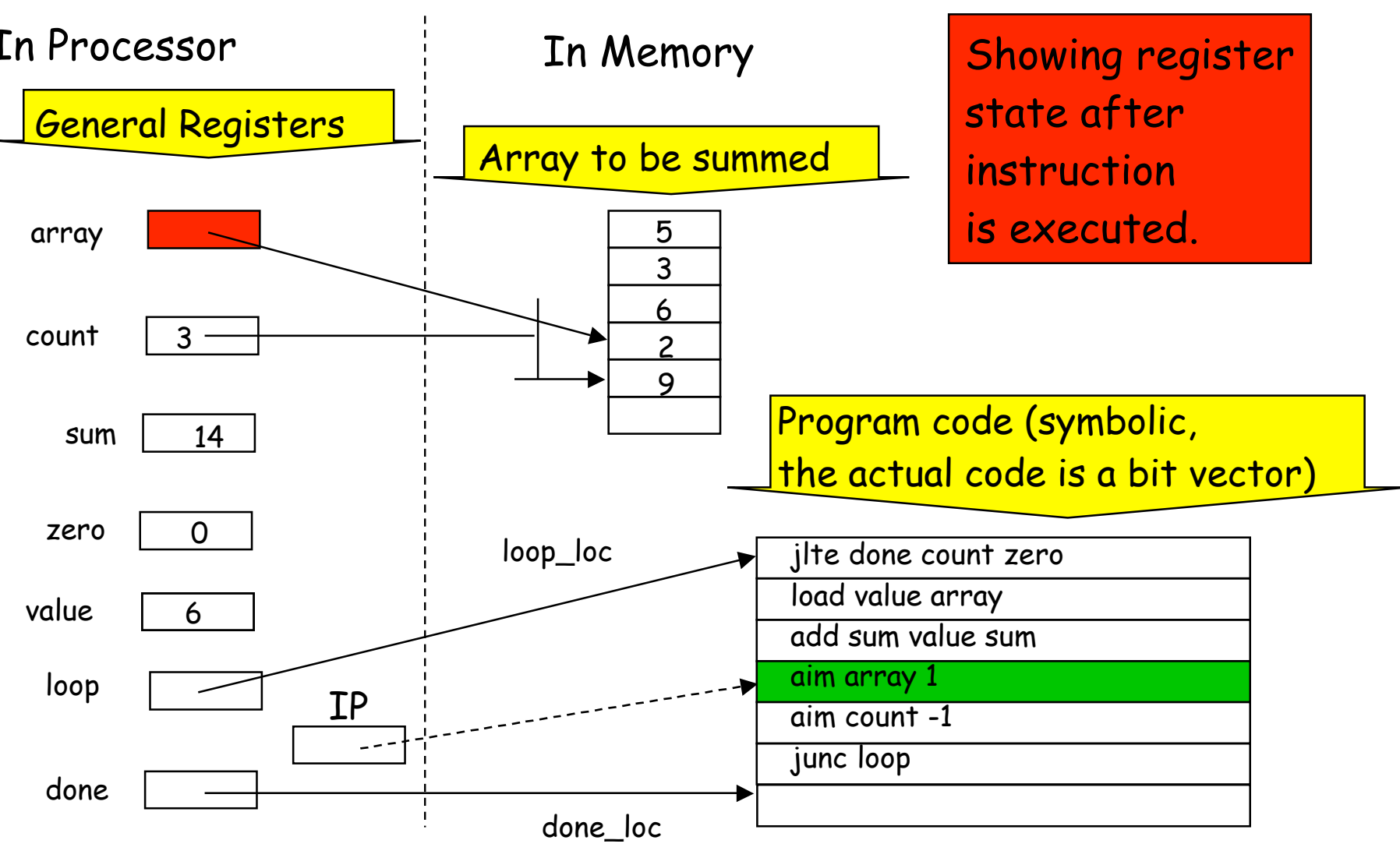

Array Summation

In Processor

General Registers

array

count 2

sum 14

zero 0

value 6

loop

done

IP

In Memory

Array to be summed

5
3
6
2
9

Showing register state after instruction is executed.

Program code (symbolic, the actual code is a bit vector)

loop_loc

jlte done count zero
load value array
add sum value sum
aim array 1
aim count -1
junc loop

done_loc

Array Summation

In Processor

General Registers

array

count 2

sum 14

zero 0

value 6

loop

done

IP

In Memory

Array to be summed

5
3
6
2
9

Showing register state after instruction is executed.

Program code (symbolic, the actual code is a bit vector)

loop_loc

jlte done count zero
load value array
add sum value sum
aim array 1
aim count -1
junc loop

done_loc

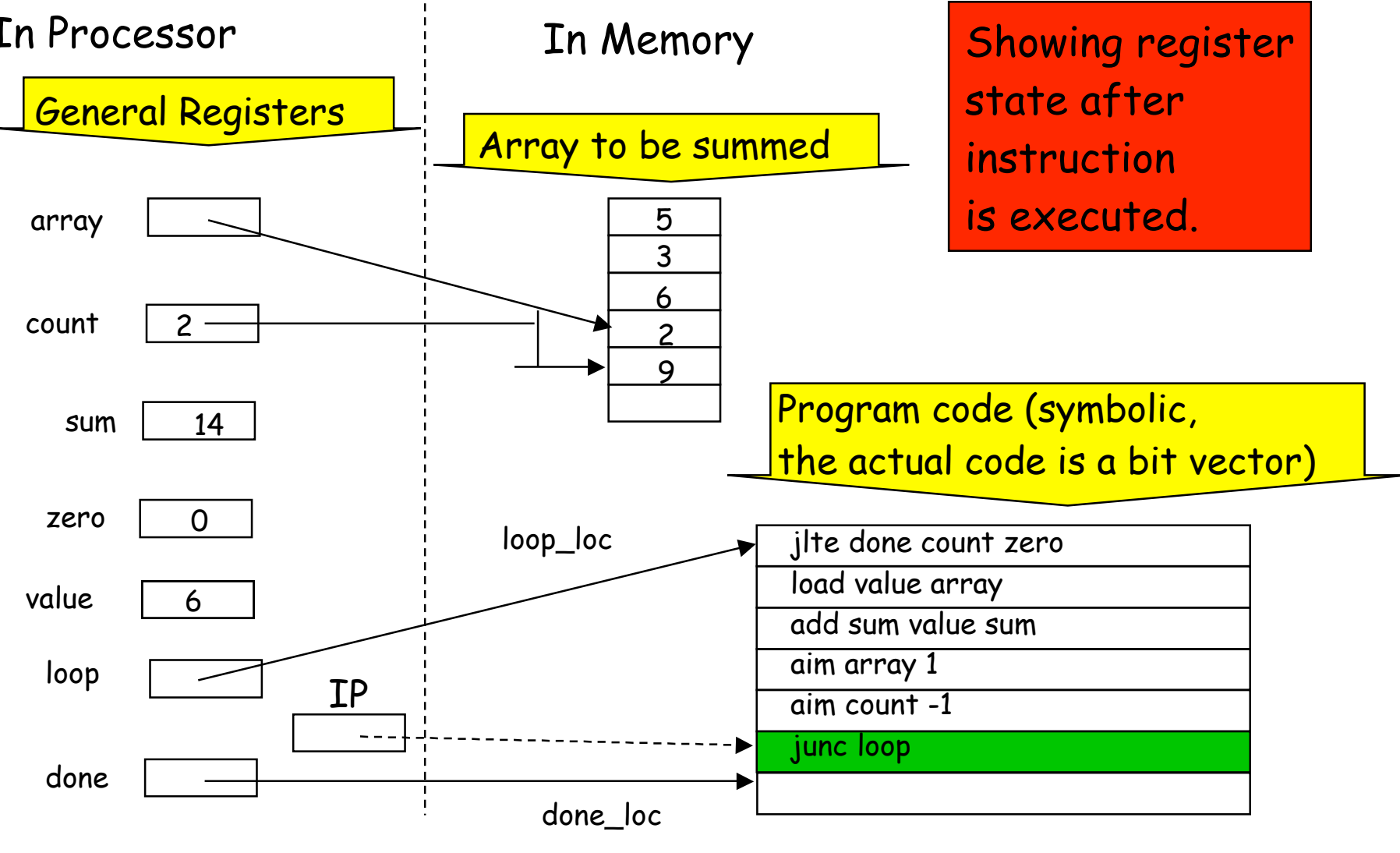

Array Summation

In Processor

General Registers

array

count 2

sum 14

zero 0

value 6

loop

done

In Memory

Array to be summed

5
3
6
2
9

Program code (symbolic,
the actual code is a bit vector)

loop_loc

jlte done count zero

load value array

add sum value sum

aim array 1

aim count -1

junc loop

done_loc

IP

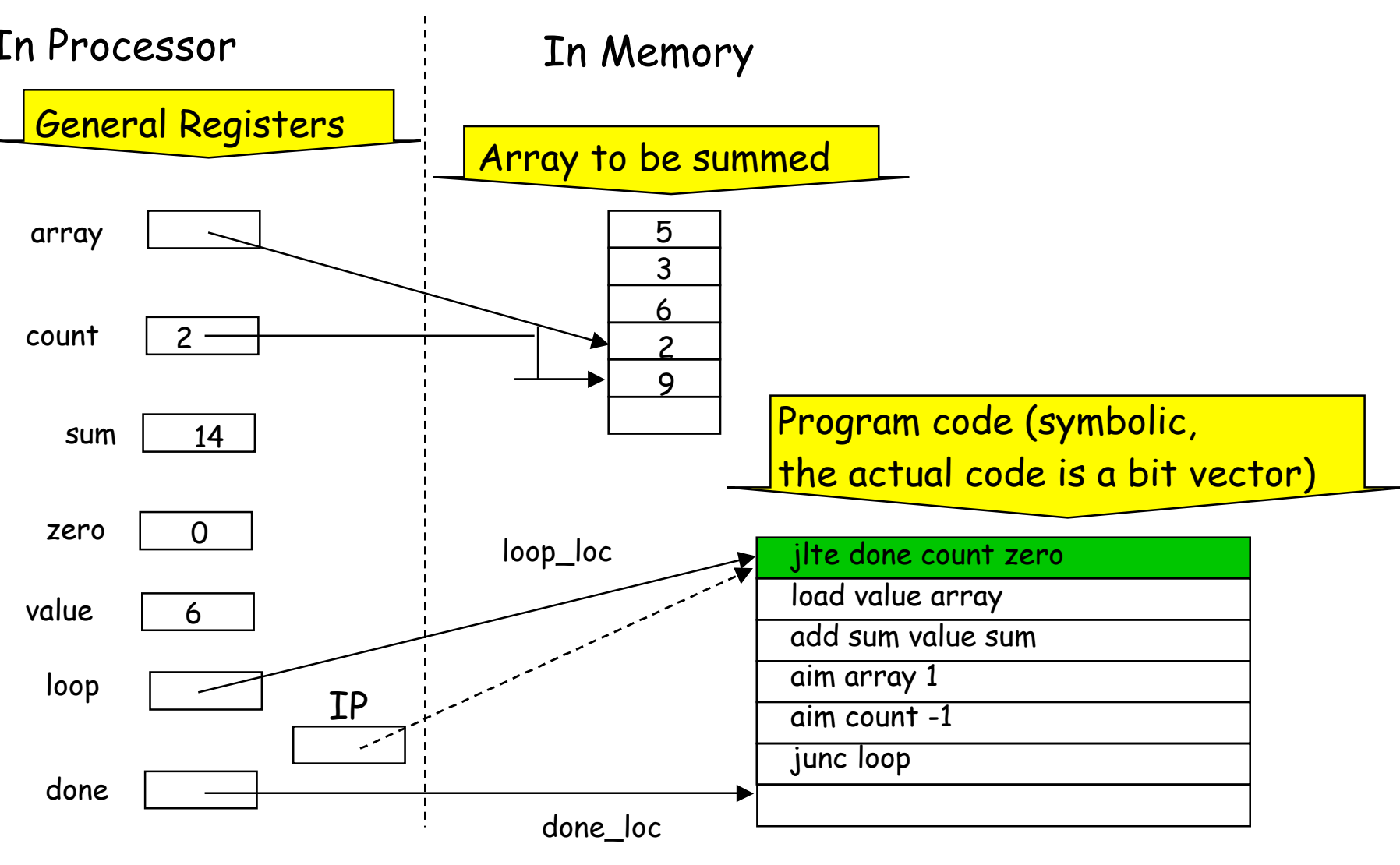

Array Summation

In Processor

General Registers

array

count 2

sum 14

zero 0

value 2

loop

done

In Memory

Array to be summed

5
3
6
2
9

Showing register state after instruction is executed.

Program code (symbolic, the actual code is a bit vector)

loop_loc

jlte done count zero
load value array
add sum value sum
aim array 1
aim count -1
junc loop

done_loc

IP

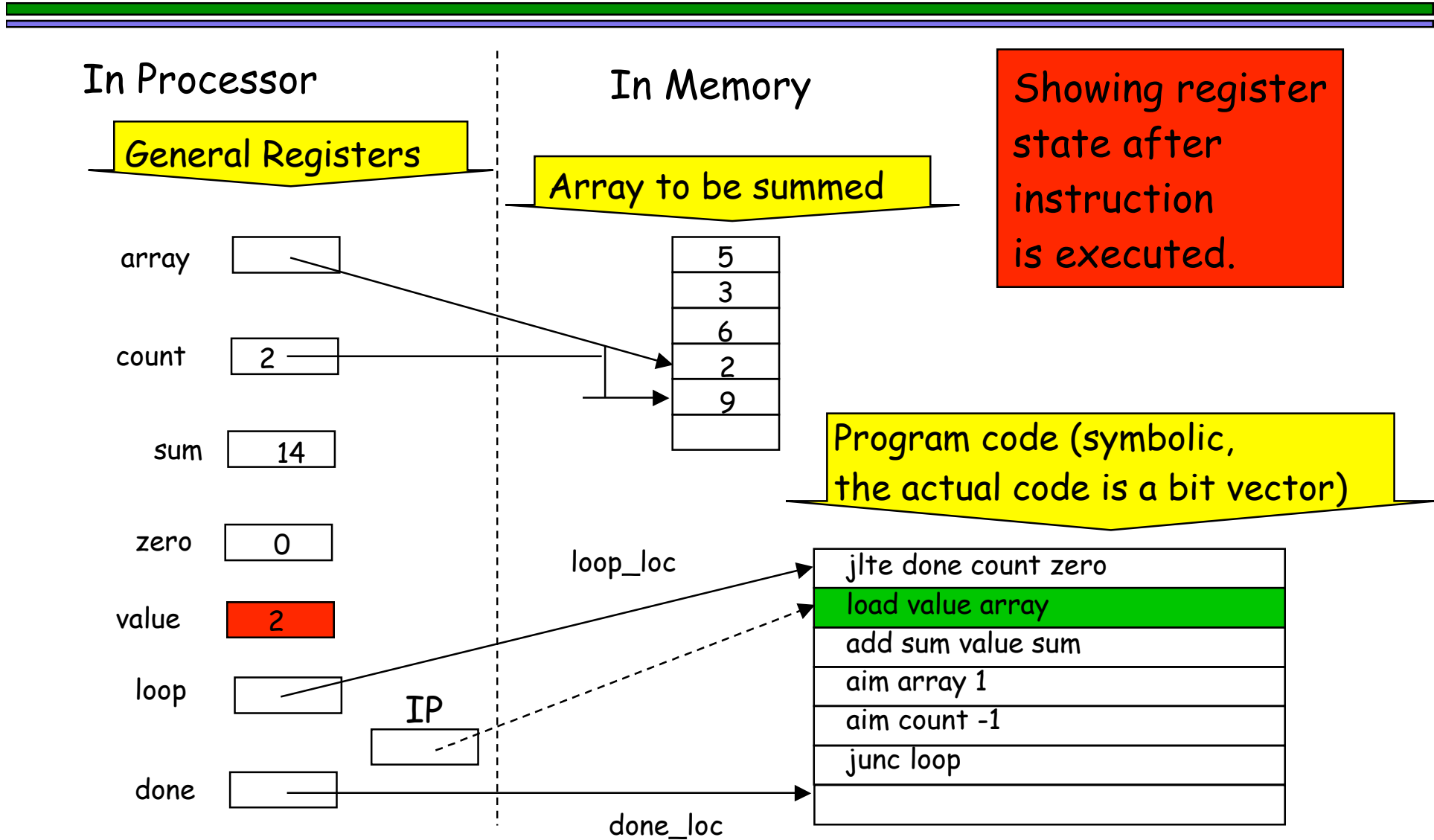

Array Summation

In Processor

General Registers

array

count 2

sum 16

zero 0

value 2

loop

done

IP

In Memory

Array to be summed

5
3
6
2
9

Showing register state after instruction is executed.

Program code (symbolic, the actual code is a bit vector)

loop_loc

jlte done count zero
load value array
add sum value sum
aim array 1
aim count -1
junc loop

done_loc

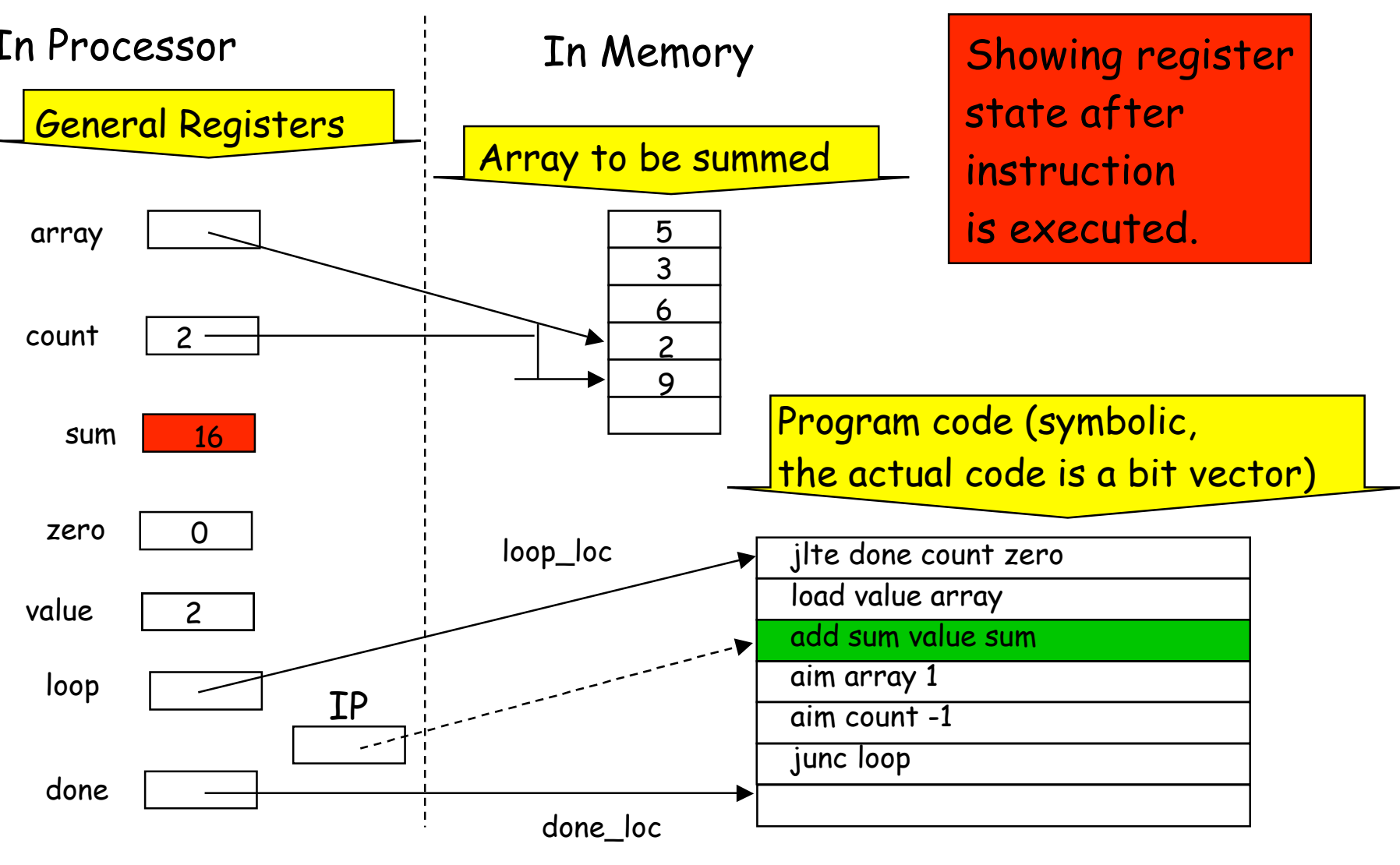

Array Summation

In Processor

General Registers

array

count 2

sum 16

zero 0

value 2

loop

done

IP

In Memory

Array to be summed

5
3
6
2
9

Showing register state after instruction is executed.

Program code (symbolic, the actual code is a bit vector)

loop_loc

jlte done count zero
load value array
add sum value sum
aim array 1
aim count -1
junc loop

done_loc

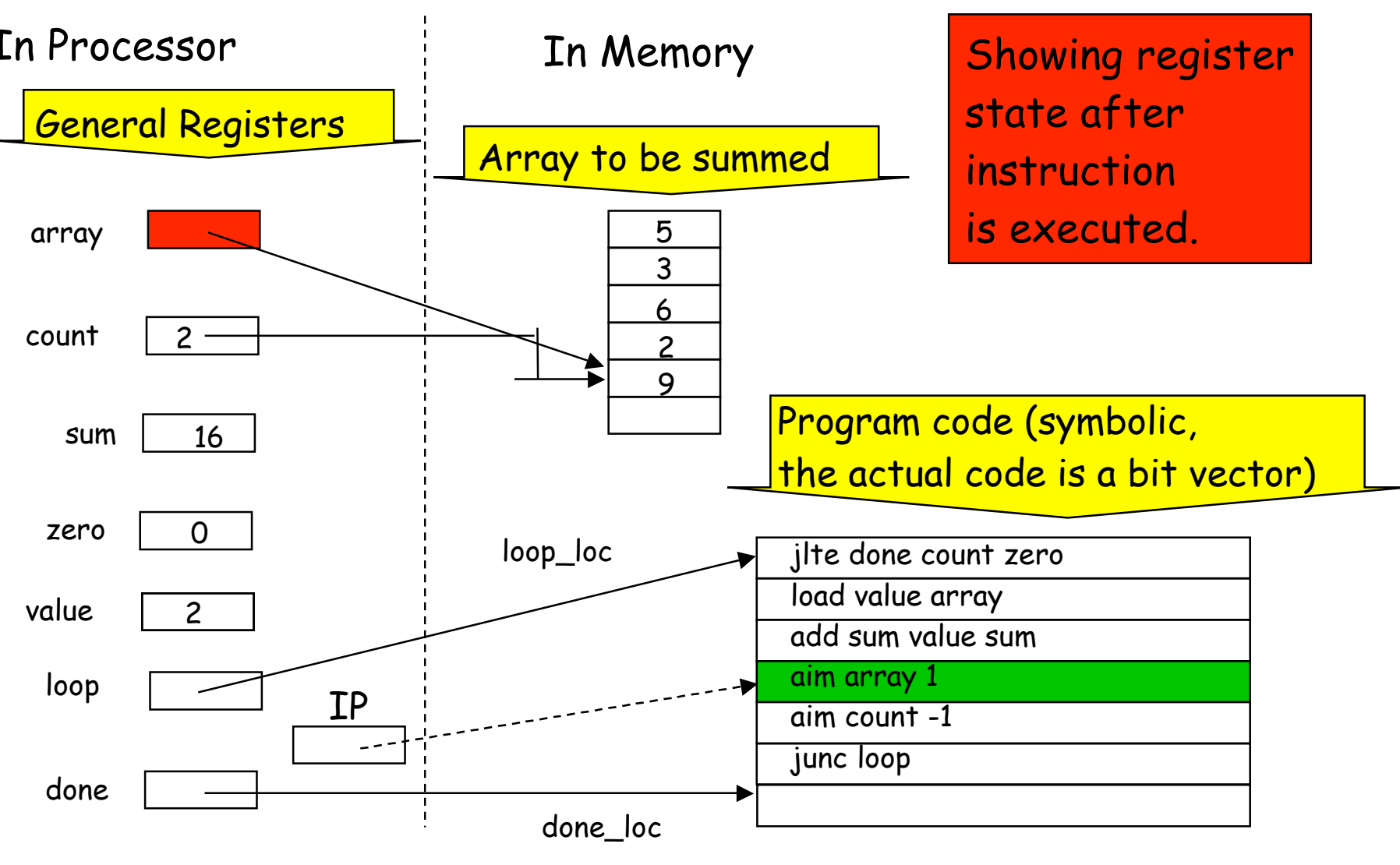

Array Summation

In Processor

General Registers

array

count 1

sum 16

zero 0

value 2

loop

done

IP

In Memory

Array to be summed

5
3
6
2
9

Showing register state after instruction is executed.

Program code (symbolic, the actual code is a bit vector)

loop_loc

jlte done count zero
load value array
add sum value sum
aim array 1
aim count -1
junc loop

done_loc

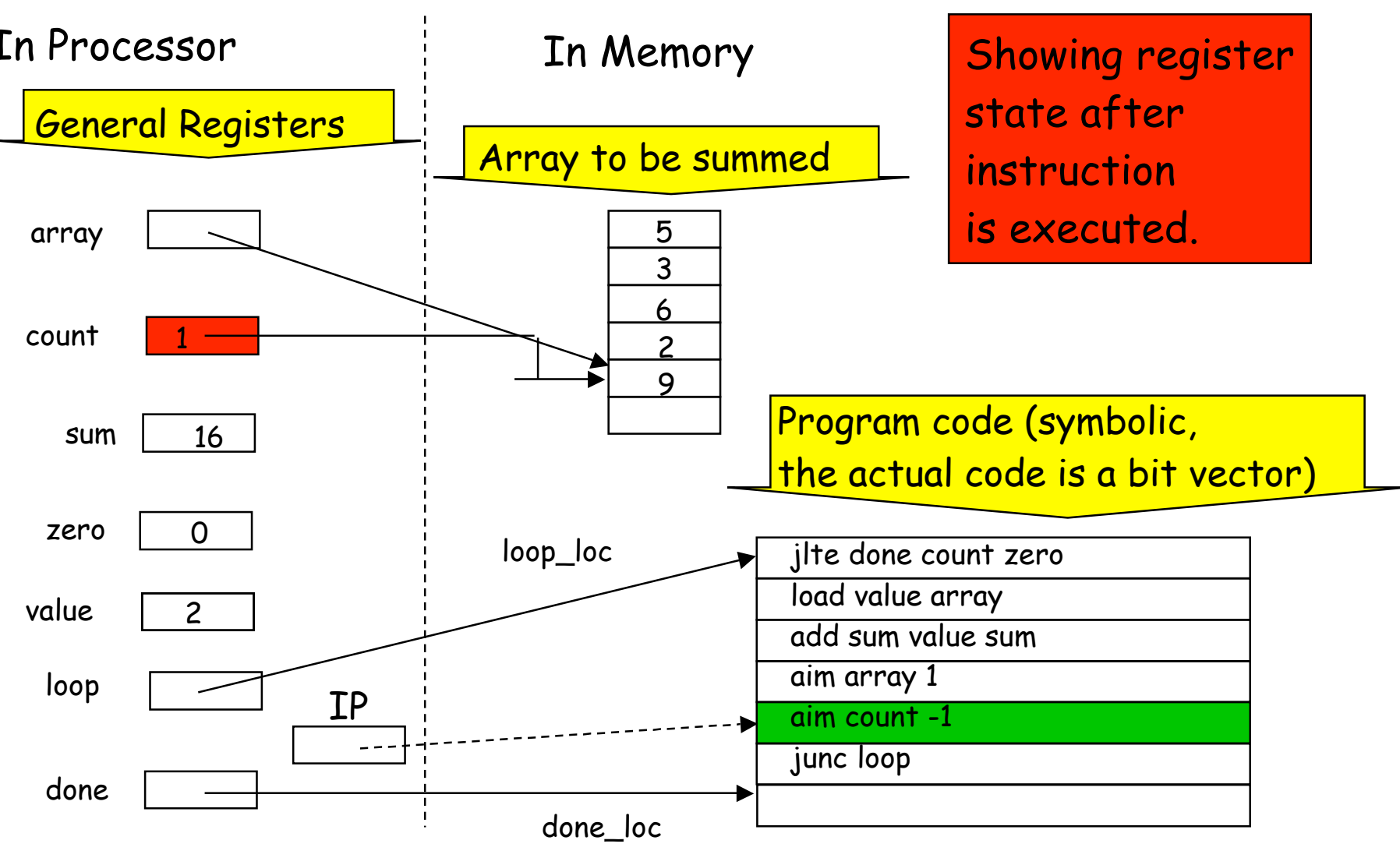

Array Summation

In Processor

General Registers

array

count 1

sum 16

zero 0

value 2

loop

done

IP

In Memory

Array to be summed

5
3
6
2
9

loop_loc

done_loc

Program code (symbolic, the actual code is a bit vector)

jlte done count zero
load value array
add sum value sum
aim array 1
aim count -1
junc loop

Showing register state after instruction is executed.

Array Summation

In Processor

General Registers

array

count 1

sum 16

zero 0

value 2

loop

done

In Memory

Array to be summed

5
3
6
2
9

Program code (symbolic,
the actual code is a bit vector)

loop_loc

jlte done count zero

load value array

add sum value sum

aim array 1

aim count -1

junc loop

IP

done_loc

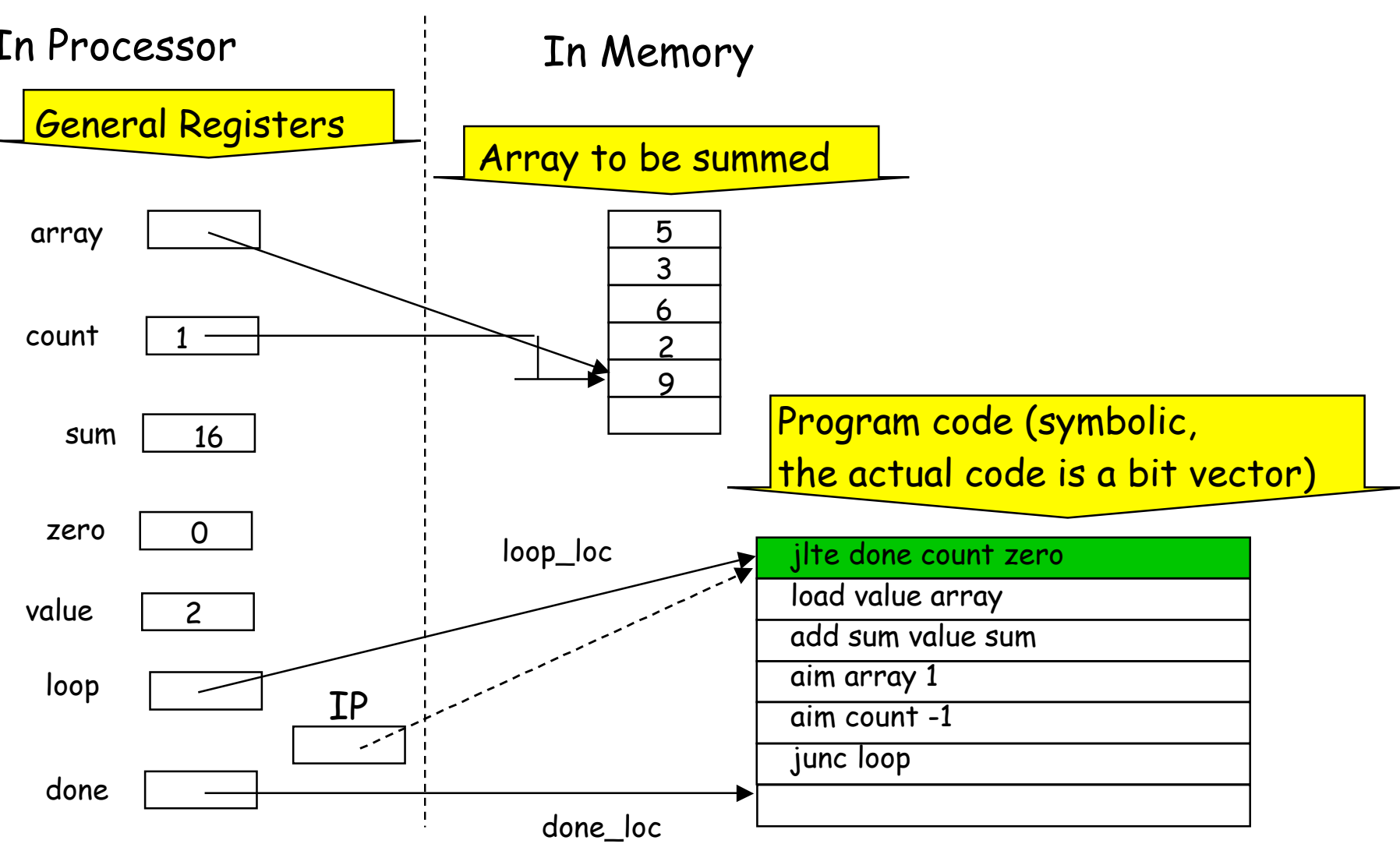

Array Summation

In Processor

General Registers

array

count 1

sum 16

zero 0

value 9

loop

done

In Memory

Array to be summed

5
3
6
2
9

Showing register state after instruction is executed.

Program code (symbolic, the actual code is a bit vector)

loop_loc

jltz done count zero
load value array
add sum value sum
aim array 1
aim count -1
junc loop

IP

done_loc

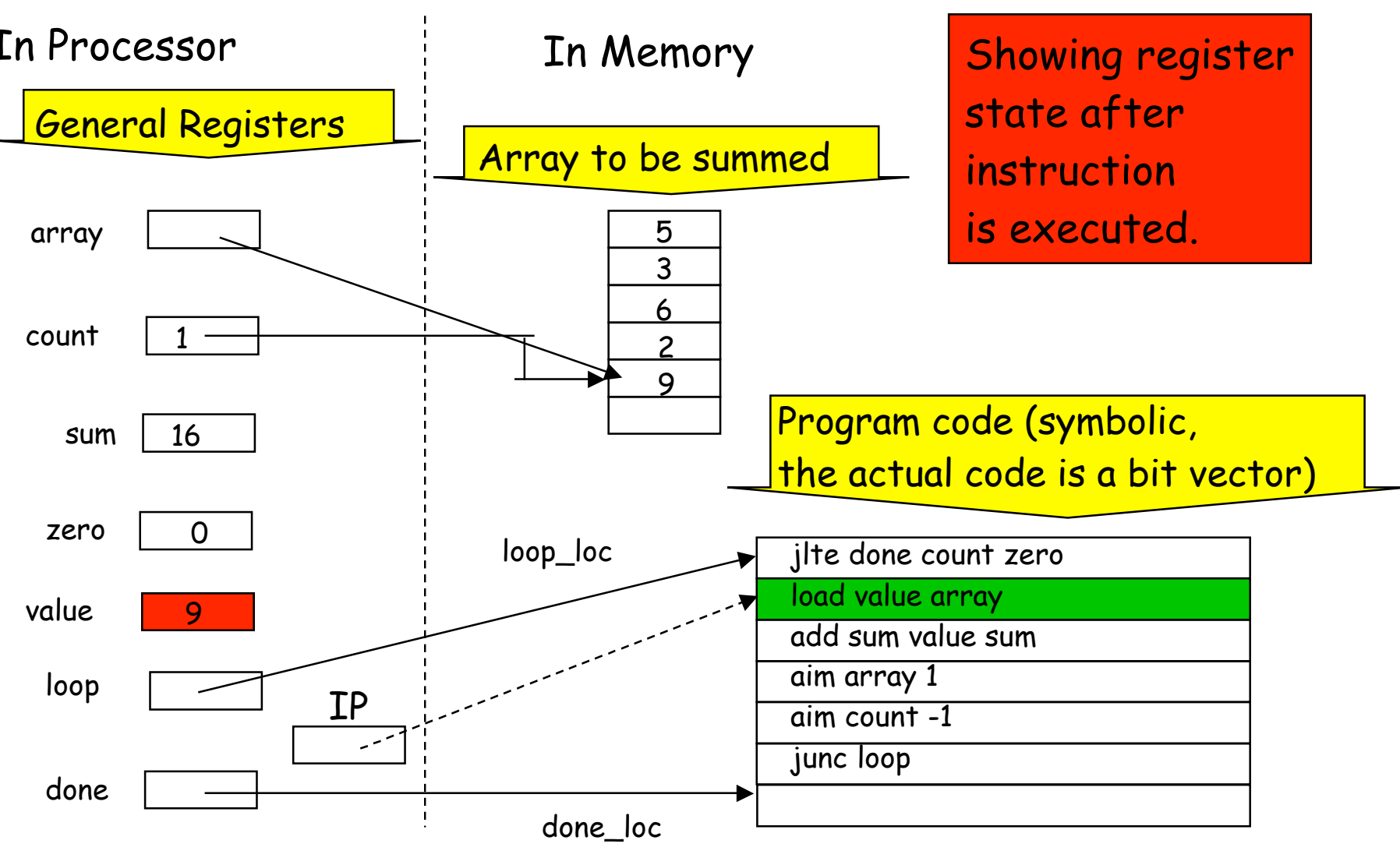

Array Summation

In Processor

General Registers

array

count 1

sum 25

zero 0

value 9

loop

done

IP

In Memory

Array to be summed

5
3
6
2
9

loop_loc

done_loc

Program code (symbolic, the actual code is a bit vector)

jlte done count zero
load value array
add sum value sum
aim array 1
aim count -1
junc loop

Showing register state after instruction is executed.

Array Summation

In Processor

General Registers

array

count 1

sum 25

zero 0

value 9

loop

done

IP

In Memory

Array to be summed

5
3
6
2
9

loop_loc

done_loc

Program code (symbolic, the actual code is a bit vector)

jlte done count zero
load value array
add sum value sum
aim array 1
aim count -1
junc loop

Showing register state after instruction is executed.

Array Summation

In Processor

General Registers

array

count 0

sum 25

zero 0

value 9

loop

done

IP

In Memory

Array to be summed

5
3
6
2
9

Showing register state after instruction is executed.

Program code (symbolic, the actual code is a bit vector)

loop_loc

jlte done count zero
load value array
add sum value sum
aim array 1
aim count -1
junc loop

done_loc

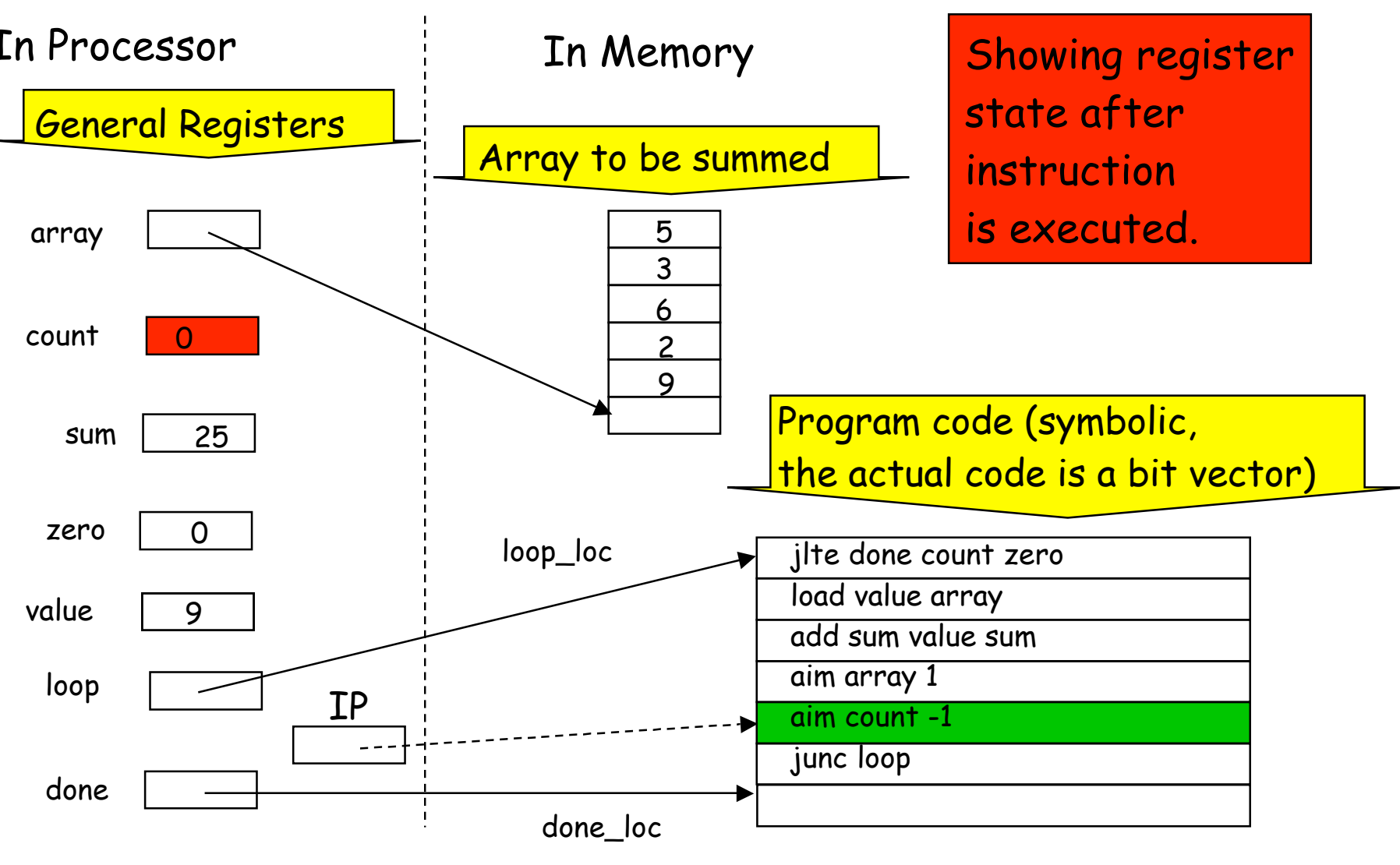

Array Summation

In Processor

General Registers

array

count 0

sum 25

zero 0

value 9

loop

done

IP

In Memory

Array to be summed

5
3
6
2
9

Showing register state after instruction is executed.

Program code (symbolic, the actual code is a bit vector)

loop_loc

jltz done count zero

load value array

add sum value sum

aim array 1

aim count -1

junc loop

done_loc

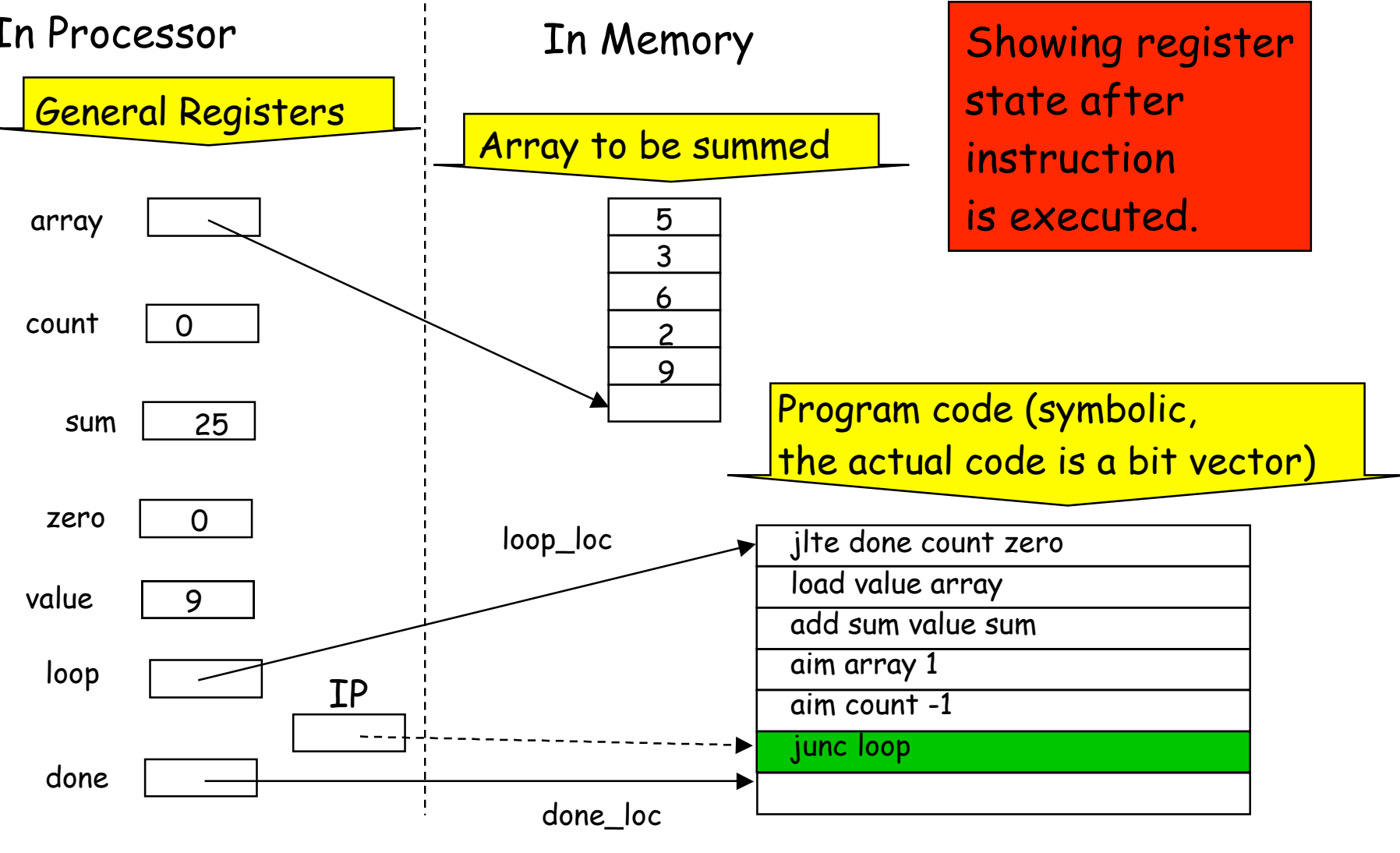

Array Summation

In Processor

General Registers

array

count 0

sum 25

zero 0

value 9

loop

done

In Memory

Array to be summed

5
3
6
2
9

Program code (symbolic,
the actual code is a bit vector)

loop_loc

jlte done count zero

load value array

add sum value sum

aim array 1

aim count -1

junc loop

done_loc

IP

IP

Array Summation

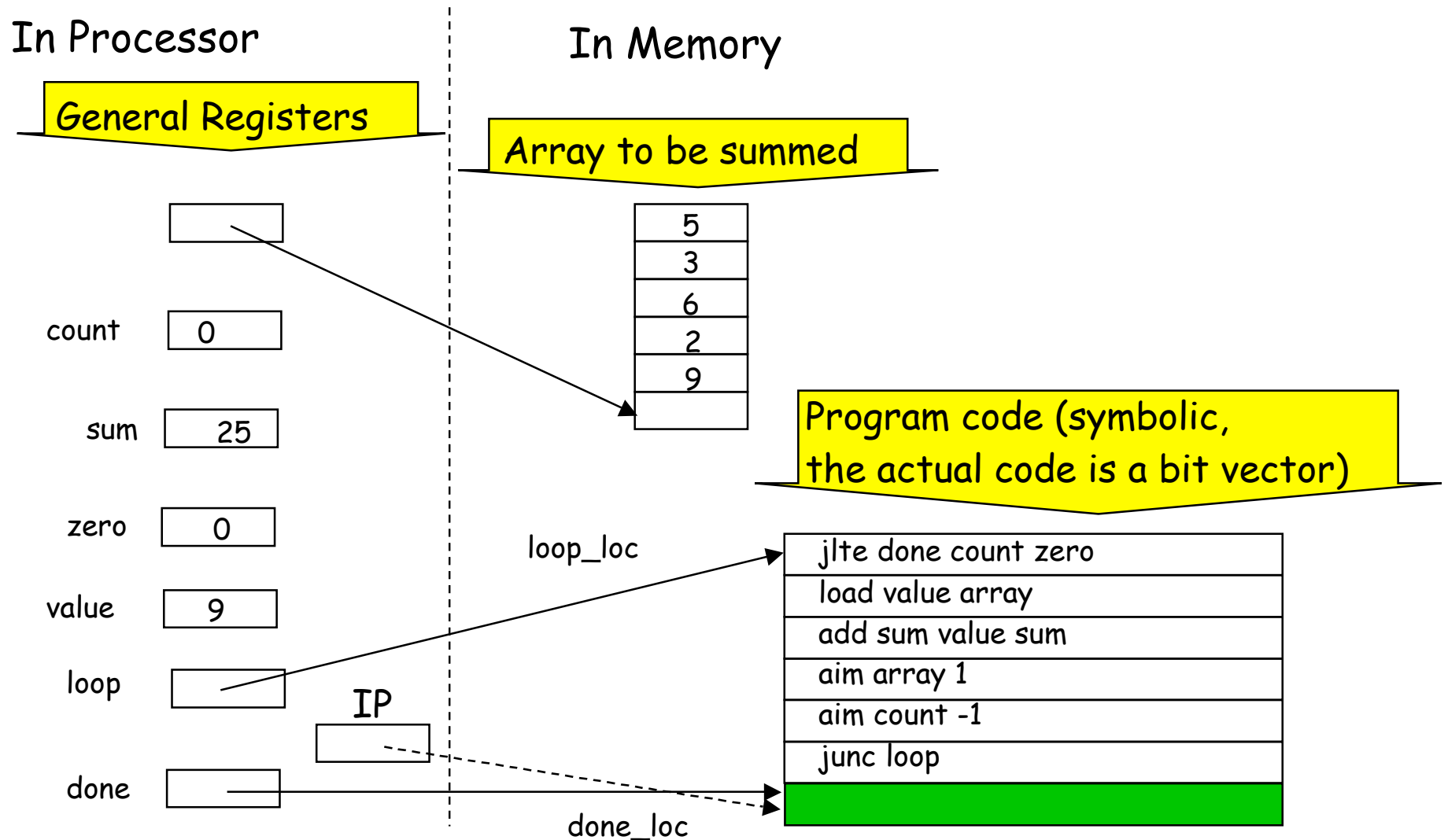

The ISC Assembler

- The ISC assembler is actually a combined assembler, loader, and tracer (for debugging).
- The executable is:
`/cs/cs60/bin/isc`
- Sample programs are in
`/cs/cs60/isc/`

The ISC Assembler

- The array summation program is in `/cs/cs60/isc/array.isc`. It includes additional code to create the array and output the result.

isc output

```
turing isc:1> isc array.isc
25
```

trace flag



```
turing isc:2> isc -t array.isc
Begin trace
```

```
line:   36 loc:    0 contents: lim      r9  (0)          0
      reg[9] = 0
```

```
. . . lots of trace output . . .
----- output -----
```

```
25
```

```
-----
line:   88 loc:   32 contents: junc     r9  (0)
      jumping unconditionally to 0
```

Implementing Procedures

- A **procedure** is just some fixed code we jump to to perform some computation.
- We put the **arguments** to the procedure into pre-agreed **standard registers**, and get the result from another register.
- The **jsub** instruction can be used to get the **return address**.

Implementing Recursion

- Recursion presents a problem: The fixed code would tend to clobber (an inelegant way of saying "over-write") the return address when the procedure calls itself.
- Also, the arguments in registers would get clobbered.

Stacks to the Rescue

- To deal with the clobbering problem, we can **save** the return address and any arguments on a **stack** allocated at a standard place in memory.
- The stack is typically an array, with a pointer to the top element.

```
lim stack_pointer save_area_loc // initialize stack pointer  
aim stack_pointer -1 // always point to top of stack
```

Example: Recursive Factorial

```
label fac // recursive factorial routine
  lim result 1 // basis is 1
  jlte return arg zero // return if count is 0 or less

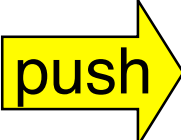
   aim stack_pointer +1 // increment stack pointer
  store stack_pointer return // save return address on stack

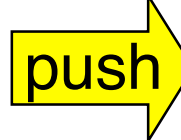
   aim stack_pointer +1 // increment stack pointer
  store stack_pointer arg // save argument on stack

  aim arg -1 // subtract 1 from argument
  jsub jump_target return // call recursively

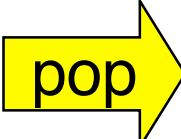
   load arg stack_pointer // restore original argument
  aim stack_pointer -1

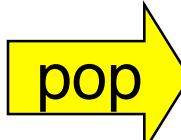
   load return stack_pointer // restore original return address
  aim stack_pointer -1

  mul result result arg // multiply by original arg
  junc return // return to caller
```

Stack trace of factorial(4)

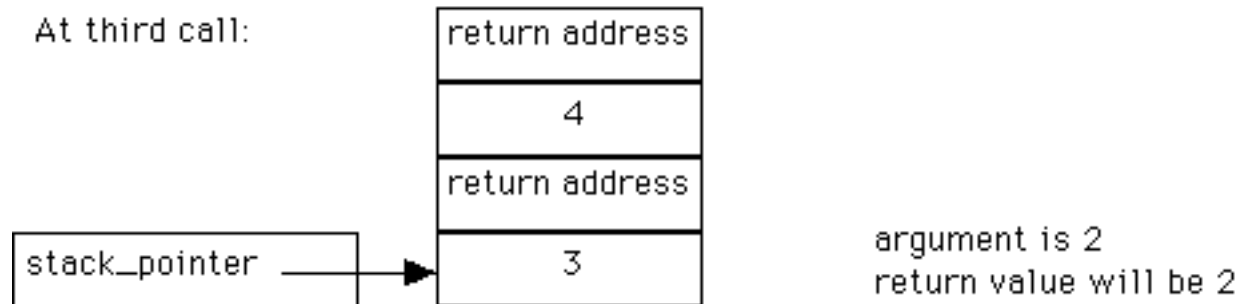
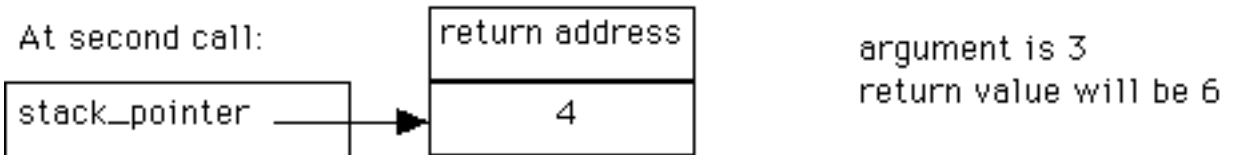

Stack trace of factorial(4)

