

Object-Oriented Database Approaches:

ODMG → JDO and beyond

Slides from Jeff Ullman,
with modifications for JDO, etc.
by Bob Keller, who borrowed liberally
from other presentations on the web

1

Object-Oriented DBMS's

- ◆ Standards group: ODMG = Object Data Management Group.
- ◆ ODL = Object **Description** Language, like CREATE TABLE part of SQL.
- ◆ OQL = Object **Query** Language, tries to replace SQL in an OO framework.

2

ODMG Framework - 1

- ◆ ODMG imagined OO-DBMS vendors implementing an OO **host language** such as C++ being extended with a DB language (OQL) that allows the programmer to transfer data seamlessly between the database and the host language.

3

ODMG Framework - 2

- ◆ ODL was used to define *persistent* classes, those whose objects may be stored permanently in the database.
 - ▶ ODL classes look like Entity sets with **binary** relationships, plus methods.
 - ▶ ODL class definitions are part of the extended language.

4

ODMG Obsolescence

- ◆ Despite its apparent virtues, the ODMG has not seemed to catch on to the extent it was hoped.
- ◆ However, it is still worthwhile, from an academic viewpoint, to review some of the ideas.
- ◆ Then we will look at JDO (Java Data Objects), which seems to be catching on, at least in the Java world.
- ◆ Microsoft has announced ObjectSpaces, which may play a similar role in its world.

5

ODL Overview

- ◆ A class declaration includes:
 1. A name for the class.
 2. Optional key declaration(s).
 3. **Extent** declaration = name for the **set of currently existing objects** of the **class**.
 4. Element declarations. An *element* is either an attribute, a relationship, or a method.

6

Class Definitions in ODL

```
class <name>
{
  <list of element declarations, separated by semicolons>
}
```

7

Attribute and Relationship Declarations

- ◆ Attributes are (usually) elements with a type that does not involve classes.

attribute <type> <name>;

- ◆ Relationships connect an object to one or more other objects of one class.

relationship <type> <name>

inverse <relationship>;

8

Inverse Relationships

- ◆ Suppose class C has a relationship R to class D .
- ◆ Then class D must have some relationship S to class C .
- ◆ R and S must be true inverses.
 - ▶ If object d is related to object c by R , then c must be related to d by S .

9

Example: Attributes and Relationships

```
class Bar {
  attribute string name;
  attribute string addr;
  relationship Set<Beer> serves inverse Beer::servedAt;
}
class Beer {
  attribute string name;
  attribute string manf;
  relationship Set<Bar> servedAt inverse Bar::serves;
}
```

The type of relationship serves is a set of Beer objects.

The :: operator connects a name on the right to the context containing that name, on the left.

10

Types of Relationships

- ◆ The type of a relationship is either
 1. A class, like Bar. If so, an object with this relationship can be connected to only one Bar object.
 2. **Set**<Bar>: the object is connected to a set of Bar objects.
 3. **Bag**<Bar>, **List**<Bar>, **Array**<Bar>: the object is connected to a bag, list, or array of Bar objects.

11

Multiplicity of Relationships

- ◆ All ODL relationships are **binary**.
- ◆ **Many-many** relationships have Set<...> for the type of the relationship and its inverse.
- ◆ **Many-one** relationships have Set<...> in the relationship of the "one" and just the class for the relationship of the "many."
- ◆ **One-one** relationships have classes as the type in both directions.

12

Example: Multiplicity

```

class Drinker { ...
  relationship Set<Beer> likes inverse Beer::fans;
  relationship Beer favBeer inverse Beer::superfans;
}
class Beer { ...
  relationship Set<Drinker> fans inverse Drinker::likes;
  relationship Set<Drinker> superfans inverse
  Drinker::favBeer;
}

```

Many-many uses Set<...> in both directions.

Many-one uses Set<...> only with the "one."

13

Another Multiplicity Example

```

class Drinker {
  attribute ... ;
  relationship Drinker husband inverse wife;
  relationship Drinker wife inverse husband;
  relationship Set<Drinker> buddies
  inverse buddies;
}

```

husband and wife are one-one and inverses of each other.

buddies is many-many and its own inverse. **Note no :: needed if the inverse is in the same class.**¹⁴

Coping With Multiway Relationships

- ◆ ODL does not support 3-way or higher relationships.
- ◆ We may simulate multiway relationships by a “connecting” class, whose objects represent tuples of objects we would like to connect by the multiway relationship.

15

Connecting Classes

- ◆ Suppose we want to connect classes X , Y , and Z by a relationship R .
- ◆ Devise a class C , whose objects represent a triple of objects (x, y, z) from classes X , Y , and Z , respectively.
- ◆ We need three many-one relationships from (x, y, z) to each of x , y , and z .

16

Example: Connecting Class

- ◆ Suppose we have Bar and Beer classes, and we want to represent the **price** at which each Bar sells each beer.
 - ▶ A many-many relationship between Bar and Beer cannot have a price attribute as it did in the E/R model.
- ◆ One solution: create class Price and a connecting class BBP to represent a related bar, beer, and price.

17

Example, Continued

- ◆ Since Price objects are just numbers, a better solution is to:
 1. Give BBP objects an attribute price.
 2. Use two many-one relationships between a BBP object and the Bar and Beer objects it represents.

18

Example, Concluded

- ◆ Here is the definition of BBP:

```
class BBP {  
    attribute price:real;  
    relationship Bar theBar inverse Bar::toBBP;  
    relationship Beer theBeer inverse Beer::toBBP;  
}
```

- ◆ Bar and Beer must be modified to include relationships, both called toBBP, and both of type Set<BBP>.

19

Structs and Enums

- ◆ Attributes can have be a **structure** (as in C) or be an **enumeration**.

- ◆ Declare with

```
attribute [Struct or Enum] <name of struct or enum>  
    { <details> }  
    <name of attribute>;
```

- ◆ Details are field names and types for a Struct, a list of constants for an Enum.

20

Example: Struct and Enum

```
class Bar {  
  attribute string name;  
  attribute Struct Addr  
    {string street, string city, int zip} address;  
  attribute Enum Lic  
    { FULL, BEER, NONE } license;  
  relationship ...  
}
```

Names for the structure and enumeration

names of the attributes

21

Reuse of Structs and Enums

- ◆ We can refer to the name of a Struct or Enum in another class definition.
 - ▶ Use the :: operator to indicate source class.

◆ Example:

```
class Drinker {  
  attribute string name;  
  attribute Struct Bar::Addr address; ...
```

Use the same street-city-zip structure here.

22

Method Declarations

- ◆ A class definition may include declarations of methods for the class.

- ◆ Information consists of:
 1. Return type, if any.
 2. Method name.
 3. Argument modes and types (no names).
 - ▶ Modes are in, out, and inout.
 4. Any exceptions the method may raise.

23

Example: Methods

```
real gpa(in string) raises(noGrades);
```

1. The method `gpa` returns a real number (presumably a student's GPA).
2. `gpa` takes one argument, a string (presumably the name of the student) and does not modify its argument.
3. `gpa` may raise the exception `noGrades`.

24

The ODL Type System

- ◆ Basic types: int, real/float, string, enumerated types, and classes.
- ◆ Type constructors:
 - ▶ Struct for structures.
 - ▶ *Collection types* : Set, Bag, List, Array, and Dictionary (= mapping from a domain type to a range type).
- ◆ Relationship types can only be a class or a single collection type applied to a class.

25

ODL Subclasses

- ◆ Usual object-oriented subclasses.
- ◆ Indicate superclass with a colon and its name.
- ◆ Subclass lists only the properties unique to it.
 - ▶ Also inherits its superclass' properties.

26

Example: Subclasses

- ◆ Ales are a subclass of beers:

```
class Ale:Beer {  
    attribute string color;  
}
```

27

ODL Keys

- ◆ You can declare any number of keys for a class.
- ◆ After the class name, add:
(key <list of keys>)
- ◆ A key consisting of more than one attribute needs additional parentheses around those attributes.

28

Example: Keys

```
class Beer (key name) { ...
```

◆ name is the key for beers.

```
class Course (key  
  (dept, number), (room, hours)) {
```

◆ dept and number form one key; so do room and hours.

29

Extents

◆ For each class there is an *extent*, the set of existing objects of that class.

- ▶ Think of the extent as the one relation with that class as its schema.

◆ Indicate the extent after the class name, along with keys, as:
(extent <extent name> ...)

30

Example: Extents

```
class Beer
  (extent Beers key name) { ...
}
```

- ◆ Conventionally, we'll use singular for class names, plural for the corresponding extent.

31

OQL

- ◆ OQL is the object-oriented query standard.
- ◆ It uses ODL as its schema definition language.
- ◆ Types in OQL are like ODL's.
- ◆ Set(Struct) and Bag(Struct) play the role of relations.

32

Path Expressions

- ◆ Let x be an object of class C .
 1. If a is an attribute of C , then $x.a$ is the value of that attribute.
 2. If r is a relationship of C , then $x.r$ is the value to which x is connected by r .
 - ▶ **Could be an object or a set of objects**, depending on the kind of r .
 3. If m is a method of C , then $x.m(\dots)$ is the result of applying m to x .

33

Running Example

```
class Sell (extent Sells) {
  attribute real price;
  relationship Bar bar inverse Bar::beersSold;
  relationship Beer beer inverse Beers::soldBy;
}
class Bar (extent Bars) {
  attribute string name;
  attribute string addr;
  relationship Set<Sell> beersSold inverse Sell::bar;
}
```

34

Running Example, Concluded

```
class Beer (extent Beers) {  
  attribute string name;  
  attribute string manf;  
  relationship Set<Sell> soldBy inverse Sell::beer;  
}
```

35

Example: Path Expressions

- ◆ Let s be a variable of type Sell, i.e., a bar-beer-price object.
 1. $s.price$ = the *price* in object s .
 2. $s.bar.addr$ = the address of the bar we reach by following the *bar* relationship in s .
 - ▶ Note the cascade of dots is OK here, because $s.bar$ is an object, **not a collection** of objects.

36

Example: Illegal Use of Dot

- ◆ We **cannot** apply the dot with a **collection** on the left --- only with a single object.
- ◆ Example (illegal), with *b* a Bar object:

`b.beersSold.price`

This expression is a set of Sell objects.
It does not have a price.

37

OQL Select-From-Where

- ◆ We may compute relation-like collections by an OQL statement:
SELECT <list of values>
FROM <list of collections and names for typical members>
WHERE <condition>

38

FROM clauses

- ◆ Each term of the FROM clause is:
<collection> <member name>
- ◆ A collection can be:
 1. The extent of some class.
 2. An expression that evaluates to a collection, e.g., certain path expressions like `b.beersSold` .

39

Example

- ◆ Get the menu at Joe's Bar.

```
SELECT s.beer.name, s.price
FROM Sells s
WHERE s.bar.name = "Joe's Bar"
```

Sells is the extent representing all Sell objects; s represents each Sell object, in turn.

Legal expressions. s.beer is a beer object and s.bar is a Bar object.

Notice OQL uses double-quotes.

40

Another Example

- ◆ This query also gets Joe's menu:

```
SELECT s.beer.name, s.price
FROM Bars b, b.beersSold s
WHERE b.name = "Joe's Bar"
```

b.beersSold is a set of Sell objects,
and s is now a typical sell object
that involves Joe's Bar.

41

Trick For Using Path Expressions

- ◆ If a path expression denotes an **object**, you can extend it with another dot and a property of that object.
 - ▶ Example: s, s.bar, s.bar.name .
- ◆ If a path expression denotes a **collection** of objects, you cannot extend it, but you can use it in the FROM clause.
 - ▶ Example: b.beersSold .

42

The Result Type

- ◆ As a default, the type of the result of select-from-where is a Bag of Structs.
 - ▶ Struct has one field for each term in the SELECT clause. Its name and type are taken from the last name in the path expression.
- ◆ If SELECT has only one term, technically the result is a one-field struct.
 - ▶ But a one-field struct is identified with the element itself.

43

Example: Result Type

```
SELECT s.beer.name, s.price  
FROM Bars b, b.beersSold s  
WHERE b.name = "Joe's Bar"
```

- ◆ Has type:
Bag(Struct(name: string, price: real))

44

Renaming Fields

- ◆ To change a field name, precede that term by the name and a colon.

- ◆ Example:

```
SELECT beer: s.beer.name, s.price
FROM Bars b, b.beersSold s
WHERE b.name = "Joe's Bar"
```

- ◆ Result type is

Bag(Struct(beer: string, price: real)).

45

Producing a Set of Structs

- ◆ Add DISTINCT after SELECT to make the result type a set, and eliminate duplicates.

- ◆ Example:

```
SELECT DISTINCT s.beer.name, s.price
FROM Bars b, b.beersSold s
WHERE b.name = "Joe's Bar"
```

- ◆ Result type is

Set(Struct(name: string, price: string))

46

Producing a List of Structs

- ◆ Use an ORDER BY clause, as in SQL to make the result a list of structs, ordered by whichever fields are listed in the ORDER BY clause.
 - ▶ Ascending (ASC) is the default; descending (DESC) is an option.
- ◆ Access list elements by index [1], [2],...
- ◆ Gives capability similar to **SQL cursors**.

47

Example: Lists

- ◆ Let joeMenu be a host-language variable of type
List(Struct(name:string, price:real))
joeMenu =
SELECT s.beer.name, s.price
FROM Bars b, b.beersSold s
WHERE b.name = "Joe's Bar"
ORDER BY s.price;

48

Example, Continued

- ◆ Now, joeMenu has a value that is a list of structs, with name and price pairs for all the beers Joe sells.
- ◆ We can find the first (lowest price) element on the list by joeMenu[1], the next by joeMenu[2], and so on.
- ◆ Example: the name of Joe's cheapest beer:

```
cheapest = joeMenu[1].name;
```

49

Example, Concluded

- ◆ After evaluating joeMenu, we can print Joe's menu by code such as:

```
cout << "Beer\tPrice\n\n";  
for (i=1; i<=COUNT(joeMenu); i++)  
    cout << joeMenu[i].name << "\t"  
    << joeMenu[i].price << "\n";
```

COUNT gives the
number of members
in any collection.

50

Subqueries

- ◆ A select-from-where expression can be surrounded by parentheses and used as a subquery in several ways, such as:
 1. In a FROM clause, as a collection.
 2. In EXISTS and FOR ALL expressions.

51

Example: Subquery in FROM

- ◆ Find the manufacturers of beers sold at Joe's:

```
SELECT DISTINCT b.manf
FROM (
  SELECT s.beer FROM Sells s
  WHERE s.bar.name = "Joe's Bar"
) b
```

Bag of Beer objects for the beers sold by Joe

Technically a one-field struct containing a Beer object, but identified with that object itself. ⁵²

Quantifiers

- ◆ Two boolean-valued expressions for use in WHERE clauses:

FOR ALL x IN <collection> : <condition>

EXISTS x IN <collection> : <condition>

- ◆ True if and only if all (resp. at least one) member of the collection satisfy the condition.

53

Example: EXISTS

- ◆ Find all names of bars that sell at least one beer for more than \$5.

```
SELECT b.name FROM Bars b
```

```
WHERE EXISTS s IN b.beersSold :
```

```
s.price > 5.00
```

↑
At least one Sell object for bar
b has a price above \$5.

54

Another Quantifier Example

- ◆ Find the names of all bars such that the only beers they sell for more than \$5 are manufactured by Pete's.

```
SELECT b.name FROM Bars b
WHERE FOR ALL be IN (
  SELECT s.beer FROM b.beersSold s
  WHERE s.price > 5.00
) : be.manf = "Pete's"
```

Bag of Beer objects (inside structs) for all beers sold by bar *b* for more than \$5.

One-field structs are unwrapped automatically, so *be* may be thought of as a Beer object. ⁵⁵

Simple Coercions

- ◆ As we saw, a one-field struct is automatically converted to the value of the one field.
 - ▶ $\text{Struct}(f : x)$ coerces to x .
- ◆ A collection of one element can be coerced to that element, but we need the operator `ELEMENT`.
 - ▶ E.g., $\text{ELEMENT}(\text{Bag}(x)) = x$.

56

Example: ELEMENT

- ◆ Assign to variable p of type real, the price Joe charges for Bud:

$p = \text{ELEMENT}(\text{$

```
SELECT s.price FROM Sells s
WHERE s.bar.name = "Joe's Bar"
AND s.beer.name = "Bud"
```

);

↑
Bag with one element, a Struct with field price and value = the price Joe charges for Bud.

57

Aggregations

- ◆ AVG, SUM, MIN, MAX, and COUNT apply to any collection where they make sense.
- ◆ Example: Find and assign to x the average price of beer at Joe's:

$x = \text{AVG}(\text{$

```
SELECT s.price FROM Sells s
WHERE s.bar.name = "Joe's Bar"
```

);

↙
Bag of structs with the prices for the beers Joe sells.

58

Grouping

- ◆ Recall SQL grouping:
 1. Groups of tuples based on the values of certain (grouping) attributes.
 2. SELECT clause can extract from a group only items that make sense:
 - ▶ Aggregations within a group.
 - ▶ Grouping attributes, whose value is a constant within the group.

59

OQL Grouping

- ◆ OQL extends the grouping idea in several ways:
 1. Any collection may be partitioned into groups.
 2. Groups may be based on any function(s) of the objects in the initial collection.
 3. Result of the query can be any function of the groups.

60

Outline of OQL GROUP BY

Initial collection
defined by
FROM, WHERE

Group by values of function(s)

Intermediate collec-
tion, with function
values and partition

Terms from SELECT clause

Output
collection

61

Example: GROUP BY

- ◆ We'll work through these concepts using an example: "Find the average price of beer at each bar."

```
SELECT barName, avgPrice: AVG(  
  SELECT p.s.price FROM partition p)  
FROM Sells s  
GROUP BY barName: s.bar.name
```

62

Initial Collection

- ◆ Based on FROM and WHERE (which is missing): FROM Sells s
- ◆ The initial collection is a Bag of structs with one field for each “typical element” in the FROM clause.
- ◆ Here, a bag of structs of the form Struct(s: *obj*), where *obj* is a Sell object.

63

Intermediate Collection

- ◆ In general, bag of structs with one component for each function in the GROUP BY clause, plus one component always called *partition*.
- ◆ The partition value is the set of all objects in the initial collection that belong to the group represented by this struct.

64

Example: Intermediate Collection

```
SELECT barName, avgPrice: AVG(  
    SELECT p.s.price FROM partition p)  
FROM Sells s  
GROUP BY barName: s.bar.name
```

↑
One grouping function. Name is barName, type is string. Intermediate collection is a set of structs with fields barName: string and partition: Set<Struct{s: Sell}>

65

Example: Typical Member

- ◆ A typical member of the intermediate collection in our example is:
Struct(barName = "Joe's Bar",
partition = {s₁, s₂, ..., s_n })
- ◆ Each member of partition is a Sell object s_i, for which s_i.bar.name is "Joe's Bar".

66

The Output Collection

- ◆ The output collection is computed by the SELECT clause, as usual.
- ◆ Without a GROUP BY clause, the SELECT clause gets the initial collection from which to produce its output.
- ◆ With GROUP BY, the SELECT clause is computed from the intermediate collection.

67

Example: Output Collection

```
SELECT barName, avgPrice: AVG(  
  SELECT p.s.price FROM partition p)
```

Extract the barName field from a group's struct.

From each member p of the group's partition, get the field s (the Sell object), and from that object extract the price.

Average these prices to create the value of field avgPrice in the structs of the output collection.

Typical output struct:
Struct(barName = "Joe's Bar",
 AvgPrice = 2.83)

68

A Less Typical Example

- ◆ Find for each beer, the number of bars that charge a “low” price ($< \$2$) and a “high” price ($> \4) for that beer.
- ◆ Strategy --- group by three values:
 1. The beer name.
 2. A boolean function that is TRUE if and only if the price is low.
 3. A boolean function that is TRUE if and only if the price is high.

69

The Query

```
SELECT beerName, low, high,  
       count: COUNT(partition)  
FROM Beers b, b.soldBy s  
GROUP BY beerName: b.name,  
         low: s.price < 2.00, high: s.price > 4.00
```

Initial collection: structs of the form
Struct(b: Beer object, s: Sell object),
where s.beer = b.

70

The Intermediate Collection

- ◆ A set of structs with four fields:
 1. beerName: string
 2. low: boolean
 3. high: boolean
 4. partition: Set<Struct{b: Beer, s: Sell}>

71

Typical Structs in the Intermediate Collection

beerName	low	high	partition
Bud	TRUE	FALSE	S_{low}
Bud	FALSE	TRUE	S_{high}
Bud	FALSE	FALSE	S_{mid}

- ◆ S_{low} , etc., are sets of Beer-Sell pairs.
- ◆ Note low and high cannot both be true; their groups are always empty.

72

The Output Collection

```
SELECT beerName, low, high,  
       count: COUNT(partition)
```

- ◆ Copy the first three components of each intermediate struct, and count the number of pairs in its partition, e.g.:

beerName	low	high	count
Bud	TRUE	FALSE	27

73

JDO Java Data Objects

74

What is JDO?

- ◆ An API for persistent objects in Java that is becoming the accepted standard (similar to what ODMG intended, except that Java is currently the only host).
- ◆ Since the host is Java, all definitions are done in Java without modification.
- ◆ A separate file (in XML) defines which classes are **persistent**.

75

Who Defines JDO?

- ◆ JDO is a result of a community process, known as the Java Community Process (JCP).
- ◆ The actual spec is here:
<http://jcp.org/aboutJava/communityprocess/final/jsr012/index2.html>
- ◆ The enabling *request* is here:
<http://www.jcp.org/en/jsr/detail?id=12#2>

76

JDO DB Applications

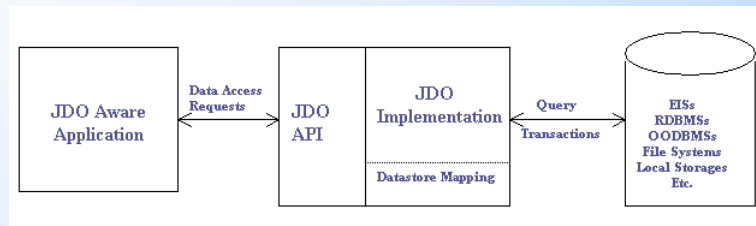

77

déjà vu?

- ◆ JDO is similar to the OODB concept demonstrated in previous slides, e.g. using Poet™.
- ◆ Poet, Inc. has revised its API to be JDO compliant, and calls it *FastObjects*™.
- ◆ Recently Poet, Inc. announced a .NET version for the Microsoft world. They also have a C++ version.

78

What about EJB and J2EE?

- ◆ EJB = "Enterprise Java Beans"
- ◆ J2EE = "Java 2 Enterprise Edition"

- ◆ JDO is compatible with the above, but provides a significant set of facilities that they don't have, thus is complementary.

79

What about JDBC?

- ◆ JDBC is used for connecting Java to SQL relational databases.

- ◆ (ODBC is the counterpart to JDBC in the Microsoft world.)

- ◆ JDO is independent of JDBC; the two can coexist.

- ◆ JDO does not replace JDBC, although some functionality could be accomplished by either.

80

Partial List of JDO Vendor Products

- ▶ **FastObjects (Poet)** - JDO built on small-footprint ODBMS that provides parallel and nested transactions, multi-thread. Provides XML import and export. built-in failover/failback. Plug-ins for JBuilder, NetBeans, Rational
- ▶ **Codigo Xpress** - Product creates a complete J2EE application and deployment with a JDO layer.
- ▶ **OJB (T. Mahler)** - ODMG 3.0 facade with dynamic mapping and on XML-based repository
- ▶ **FrontierSuite for JDO (ObjectFrontier)** - Frontier Suite is a cross-platform JDO and EJB persistence manager that provides very wide connectivity.
- ▶ **JRelay (ObjectIndustries)** - JDO-compliant source-code enhancer
- ▶ **Orient Technologies ODBMS** -Orient ODBMS Just Edition is a small-footprint high speed ODBMS that supports ODMG plus JDO and a SQL-92 subset
- ▶ **Open Fusion (PrismTech)** - API implements JDO 0.8 - maps Java classes to RDBMS schema See [data sheet and diagram](#).
- ▶ **IntelliBO 2 (Signsoft)** - Graphical development environment generates classes and Swing components from RDBMS tables and provides JBuilder integration. JDO: "fast adaptive" Class Enhancer. Run time supports caching, many RDBMS, XADatasource, JNDI DataSource optimistic/pessimistic locking.
- ▶ **KodoJDO (SolarMetric)** - Database access without coding SQL or major source code changes; implements vast majority of JDO final spec - including query filters and maps supports JDBC 1.x, 2, JBoss, WebLogic, a number of RDBMSs.
- ▶ **Rexip JDO (TCCybersoft)** - JDO implementation

81

Object Categories

- ◆ **transient:** Object disappears when application ends (as in conventional applications).
- ◆ **persistent:** Object persists after application ends.

82

A Consequence of Persistence

- ◆ Recall that in Java objects are deleted automatically by garbage collection.
- ◆ For persistent objects, **explicit deletion** is required, for it is never known when the object might be subsequently required.

83

JDO Objectives

- ◆ **Transparent** persistence
 - ▶ class developers “generally unaware” of persistence [?]
- ◆ Data store **independence**
 - ▶ relational, object, hierarchical databases
 - ▶ file systems
- ◆ Range of implementations
 - ▶ embedded (J2ME, Connected Device Configuration)
 - ▶ two tier (J2SE)
 - ▶ enterprise (J2EE, EJB)

84

JDO Object Model

- ◆ Persistence-**Capable** classes
 - ▶ most user-defined classes
 - ▶ exceptions: JNI (C code), subclasses of some System classes
- ◆ Persistent field types
 - ▶ all primitive types
 - ▶ interface types treated as java.lang.Object
 - ▶ reference types (with some restrictions)

85

States of Objects (1 of 2)

- ◆ JDO defines **ten** possible states of an object:
 - ▶ **Transient**: Ordinary Java objects; has no JDO identity.
 - ▶ **Persistent-New**: A newly-created persistent object.
 - ▶ **Persistent-Clean**: A persistent object with no uncommitted changes.
 - ▶ **Persistent-Dirty**: A persistent object with uncommitted changes.
 - ▶ **Persistent-Deleted**: A persistent object that has been explicitly deleted.

86

States of Objects (2 of 2)

- ◆ Object States, continued:
 - ▶ **Hollow:** A persistent object, but values have been loaded from the data store (usually transparent to the application).
 - ▶ **Other optional transactional states**

87

Life Cycle Views

- ◆ There are several different life cycles for JDO objects. We just present a few of them.

88

Life Cycle: Explicit Persistence

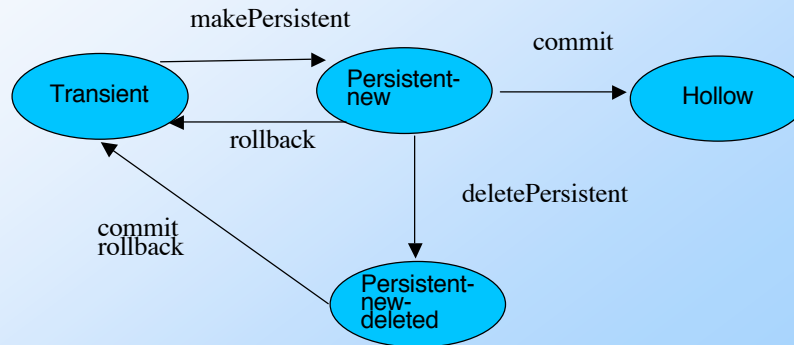

89

Transitive Persistence

- ◆ If A is persistent, and A refers to B, then B is automatically persistent.
- ◆ So if there is a **root** object for the application, just making it persistent is enough to make everything persistent.
- ◆ Of course, we might not want *everything* to be persistent.

90

A Simple Example

```
PersistenceManagerFactory factory =
    JDOHelper.getPersistenceManagerFactory (...);

PersistenceManager pm = JDOFactory.getPersistenceManager();

Transaction trans = pm.currentTransaction();

User user =
    new User("ron", "Ron Hitchens", "ron@ronsoft.com");
Address addr =
    new Address("123 Main St.", "Smallville", "CA", "12345");

user.setAddress(addr);

trans.begin();
pm.makePersistent(user); // Makes addr persistent also!
trans.commit();
pm.close();
```

91

Life Cycle: Data Store

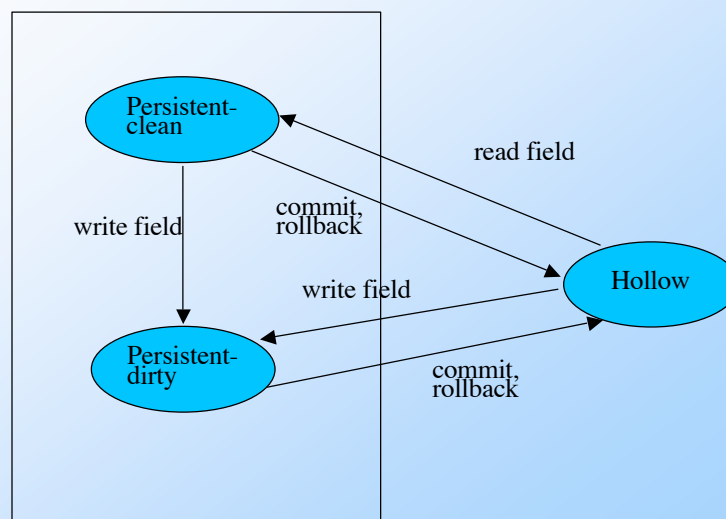

92

Transactional Persistence

- ◆ “Transactional persistence” means that
 - ▶ Old values are cached at the start of the transaction.
 - ▶ In the event of a **rollback** (an alternative to **commit**) the old values are restored, leaving the object unchanged.
- ◆ This feature is an **option** rather than a requirement for a JDO implementation.

93

The Other Aspect of Transactions

- ◆ **Concurrency control:** Objects being read by a transaction will not simultaneously be modified by another transaction.
- ◆ This can be useful even for objects that are not persistent.

94

JDO Runtime Environment

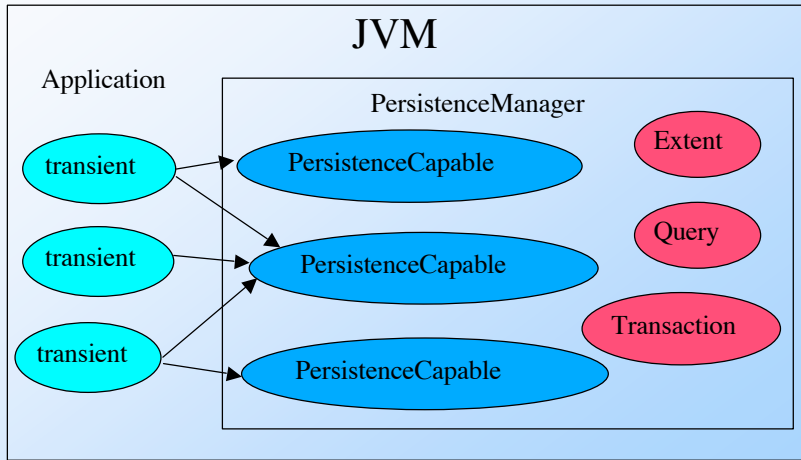

95

Compilation Steps

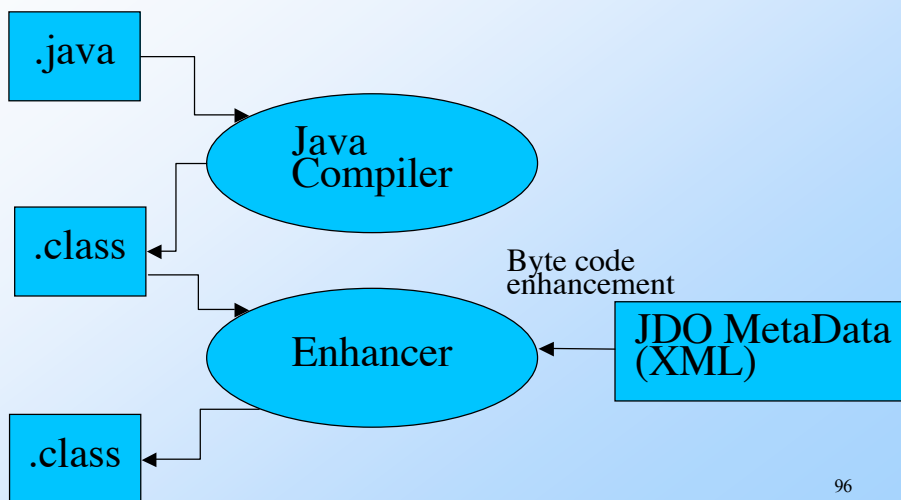

96

A More Complex Example (1/6)

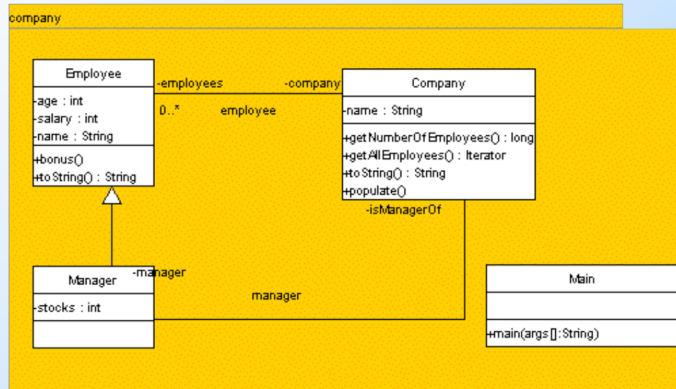

97

A More Complex Example (2/6)

```
package company;

import java.util.*;
import java.lang.String;
import java.util.Iterator;

public class Company {

    private String name;
    private Vector employees = new Vector();
    private Manager manager;

    public String getName() {
        return name;
    }
    public void setName(String name) {
        this.name = name;
    }

    public Vector getEmployees() {
        return employees;
    }
}
```

98

A More Complex Example (3/6)

```
package company;

import java.util.*;
import java.lang.String;
import javax.jdo.*;

public class Main {

    public static void main(String args[] ) {
        PersistenceManagerFactory pmf;
        PersistenceManager pm;
        Transaction tx;
        Properties prop = new Properties();
        try {
            prop.put ("javax.jdo.PersistenceManagerFactoryClass", args [0]);
            pmf = JDOHelper.getPersistenceManagerFactory (prop);
            pmf.setConnectionDriverName (args [1]);
            pmf.setConnectionURL (args [2]);
            pm = pmf.getPersistenceManager ();
            tx = pm.currentTransaction ();
```

99

A More Complex Example (4/6)

```
tx.begin ();
Company company = new Company ();
pm.makePersistent (company);
company.setName ("ACME");

Employee employee = new Employee ();
employee.setName ("John");
employee.setAge (30);
employee.setSalary (40000);
employee.setCompany (company);

employee = new Employee ();
employee.setName ("Joe");
employee.setAge (25);
employee.setSalary (30000);
employee.setCompany (company);
tx.commit ();
```

100

A More Complex Example (5/6)

```
tx.begin();
Manager manager = new Manager();
manager.setName("Jack");
manager.setAge(40);
manager.setSalary(100000);
manager.setStocks(1000);
company.setManager(manager);
company.addEmployees(manager);
tx.commit();

tx.begin();
company = new Company();
pm.makePersistent(company);
company.setName("MacroSoft");
manager = new Manager();
manager.setName("Bill");
manager.setAge(50);
manager.setSalary(1000000);
manager.setStocks(1000000);
company.setManager(manager);
company.addEmployees(manager);
company.populate();
tx.commit();
```

101

A More Complex Example (6/6) Showing the use of a Query

```
tx.begin();
javax.jdo.Query q = pm.newQuery(Employee.class,"salary<150000");
q.setOrdering("salary descending");
Collection result = (Collection)q.execute();
Iterator it = result.iterator();
while (it.hasNext()) {
    employee = (Employee)it.next();
    employee.bonus();
    System.out.println(employee+" salary = "+employee.getSalary());
}

tx.commit();
pm.close();

} catch(Exception e){
    e.printStackTrace();
}
```

102

Ways to Retrieve Object

- ◆ By query, in JDOQL (pass a string that represents the query)
- ◆ By navigation:
 - ▶ Direct object reference
 - ▶ Iterating over extent for the class

103

Getting to the First Object

- ❖ Application may access a “closure of instances” navigated to from one instance
- ❖ 3 ways to get the first instance:
 - ▶ **PersistenceManager.getObjectById()**
 - must be able to construct the Object ID
 - ▶ **PersistenceManager.getExtent()**
 - must navigate extent of all persistent instances
 - ▶ JDOQL

104

Life Cycle of PersistenceCapable

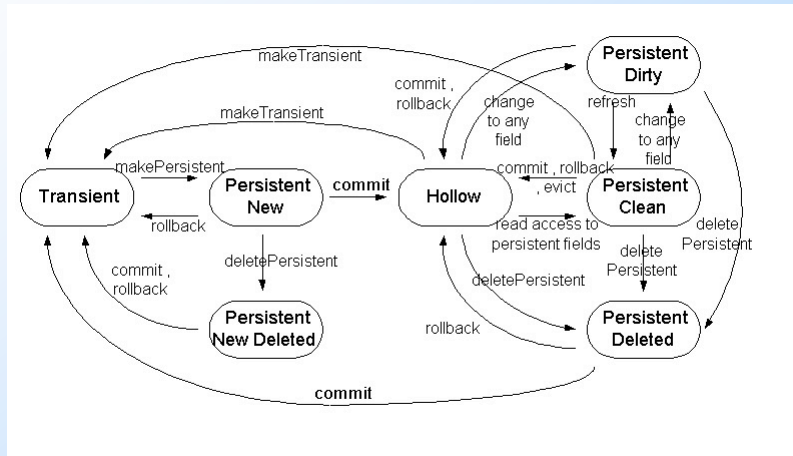

105

Another View of Previous

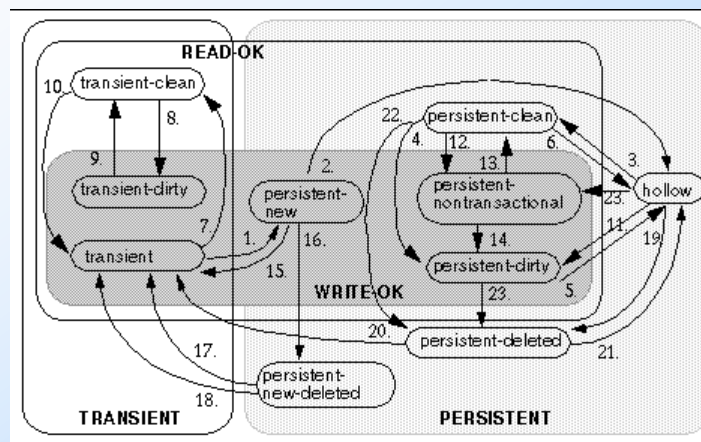

106

The Corresponding File metadata.jdo

```
<?xml version="1.0"?>
<!DOCTYPE jdo>
<jdo>
  <package name="company">
    <class name="Company">
      <field name="employees">
        <collection element-type="company.Employee"/>
      </field>
    </class>
    <class name="Employee"/>
    <class name="Manager" persistence-capable-superclass="company.Employee"/>
  </package>
</jdo>
```

107

Summary of Enhancement

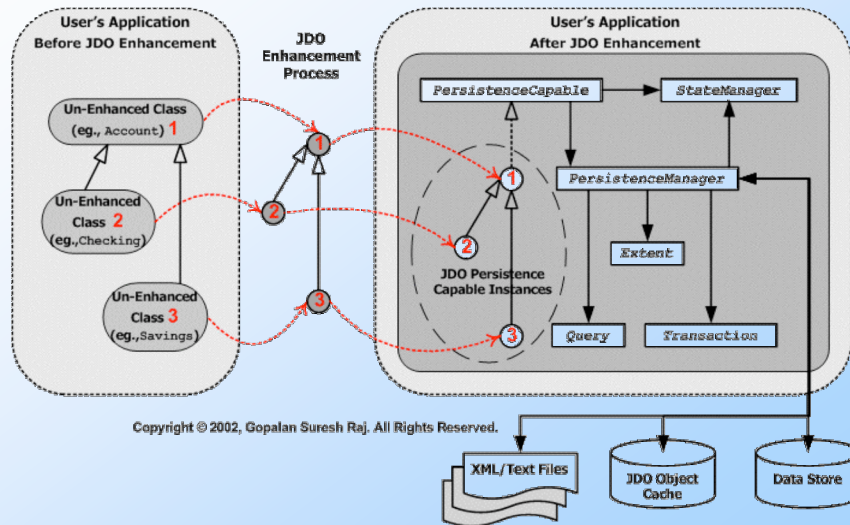

108

Identity, Equality Issues

- ◆ Java **identity** implemented by JVM
 - ▶ `o1 == o2`
- ◆ Object **equality** implemented by class developer
 - ▶ `o1.equals(o2)`
- ◆ **JDO Identity** implemented by JDO vendor
 - ▶ `o1.jdoGetObjectId().equals(o2.jdoGetObjectId())`
 - Primary key (defined by application, enforced in db)
 - Database (managed by db)
 - Non-managed (e.g. tables without primary key)

109

Object Uniqueness

- ◆ JDO instances representing the same data store object exist only once per PersistenceManager, regardless of how the instance is obtained:
 - ▶ query
 - ▶ navigation
 - ▶ getObjectById
 - ▶ getTransactionalInstance

110

Inheritance

- ◆ Polymorphism is supported
 - ▶ Base type must be PersistenceCapable
 - ▶ Persistent super classes must be listed in metadata definition
 - ▶ Queries may return subclasses, if requested
- ◆ Implementation defines table mapping strategy
 - ▶ Single Table, Class Table, Concrete Table
- ◆ Interfaces may not be directly persisted

111

JDO API

- ◆ Six interfaces
 1. PersistenceManagerFactory
 2. PersistenceManager
 3. Transaction
 4. Extent
 5. Query
 6. InstanceCallbacks

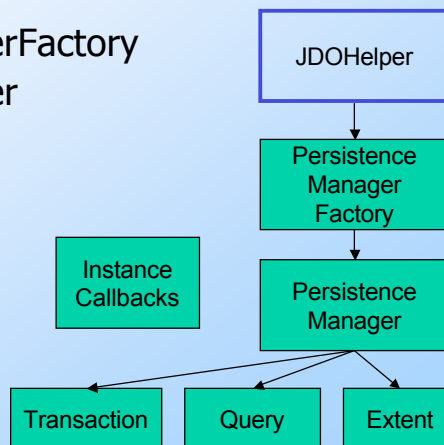

112

Instance Callbacks

- ◆ Events **trigger** functions in DBMS
- ◆ PersistenceCapable class that provides callback methods implements this interface
- ◆ Methods
 - ▶ jdoPostLoad()
 - ▶ jdoPreStore()
 - ▶ jdoPreClear()
 - ▶ jdoPreDelete()

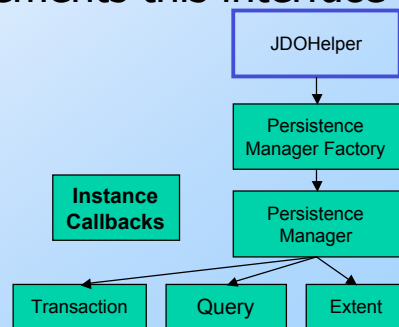

113

JDO Restrictions

- ◆ Not all objects are persistable
 - ▶ Streams, Sockets, many system classes, etc
- ◆ Collections must be homogenous
- ◆ Maps may have restrictions on keys
- ◆ List ordering may not be preserved
- ◆ Objects cannot migrate between PersistenceManager instances
- ◆ Persisted objects cannot outlive their owning PersistenceManager

114

Discussion

- ◆ Discuss JDO-style vs. Relational (SQL) style.
- ◆ List benefits of each over the other.
- ◆ If you had to make a choice of just one for developing a DB application, which capability would you rather have?

115

JDO in the J2EE Architecture (replacing Entity Java Beans)

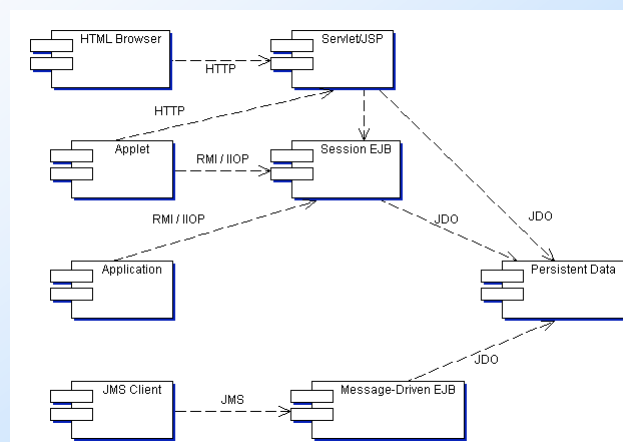

116

JDO in the J2EE Architecture (delegating from Entity Java Beans)

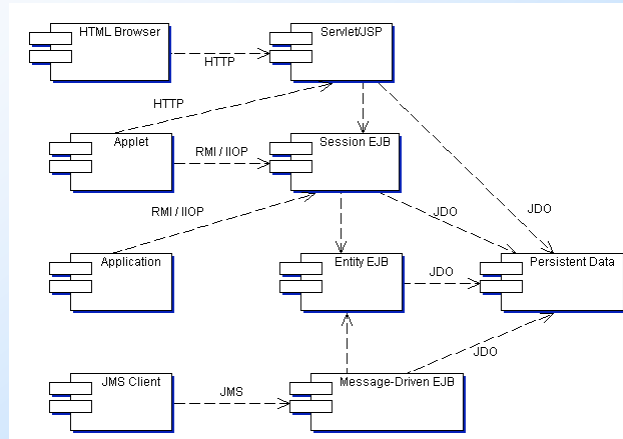

117

Some JDO References

- ◆ Java Specification Request 12 to the Java Community Process
 - ▶ <http://www.jcp.org/en/jsr/detail?id=12#1>
- ◆ java.sun.com
 - ▶ <http://java.sun.com/products/jdo/>
- ◆ JDO Public Access at sun.com
 - ▶ <http://access1.sun.com/jdo/>
- ◆ JDO Central – Developer’s Community for Java Data Objects
 - ▶ <http://www.jdocentral.com/>
- ◆ Java Skyline
 - ▶ <http://www.javaskyline.com/database.html>
- ◆ O’Reilly : Using Java Data Objects
 - ▶ www.onjava.com/lpt/a/1372
- ◆ Hands-on Java Data Objects - IBM: Java Technology
 - ▶ <http://www-105.ibm.com/developerworks/education.nsf/java-onlinecourse-bytitle/8CE3AB0807C9FA5786256BE200692408?OpenDocument>

118

URLs from which I took stuff (diagrams, links)

- ◆ http://conferences.oreillynet.com/presentations/os2003/hitchens_ron.ppt
- ◆ http://access1.sun.com/jdo/JDO_0.6_Overview_00-04-05.ppt
- ◆ <http://www.cs.umd.edu/class/fall2003/cmsc838p/jdo.ppt>
- ◆ <http://students.depaul.edu/%7Elahrens/se690/deliver/JDO.ppt>
- ◆ <http://www.javasig.com/Archive/lectures/JavaSIG-JavaDataObjects.ppt>

119

JDO Books

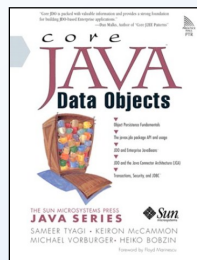



****+

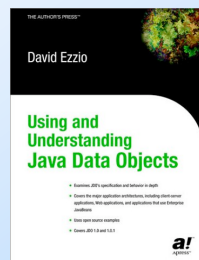

****+



(Amazon customer ratings)

120