

Computers: What can't they do!
Computers: What can't they do?

Part 2: State Machines

March 11–12, 2012

CS 60: Principles of Computer Science

IDEALIZED COMPUTERS



We need a precise (mathematical) definition.

Abstract away details that might change.

- ✓ Operating System
- ✓ Processor speed
- ✓ Memory capacity
- ✓ Power source (electricity, natural gas, dilithium, ...)
- ✓ Construction materials (silicon, graphene, legos, ...)
- ✓ Programming language (Java, Racket, Prolog, HMMM, ...)
- ✓ Architecture (single core, multicore, manycore, GPU, VLIW, ...)
- ✓ Data representation (ASCII, Unicode, binary, trinary, ...)

TODAY'S IDEALIZED COMPUTER

State Machine, which

- ✓ A set of possible “configurations” (states)
- ✓ Rules for how the system proceeds from one state to another
 - ▶ Depends on current state *and* current input
- ✓ Accept or reject, based on the input this far.

WHAT IS A STATE?

The *state* of a system at some instant consists of the all internal information needed to figure out how to proceed.

State?



<http://www.flickr.com/photos/alexbrn/5035170693>

State?

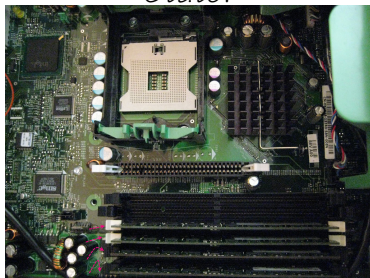

<http://www.flickr.com/photos/cambodia4kidsorg/3019948738>

Many systems have
more than 50 states!



FINITE STATE MACHINES

A *finite state machine* is a state machine with finitely many possible states.

Finite State?

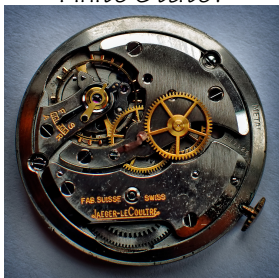

<http://www.flickr.com/photos/alexbrn/5035170693>

Finite State?

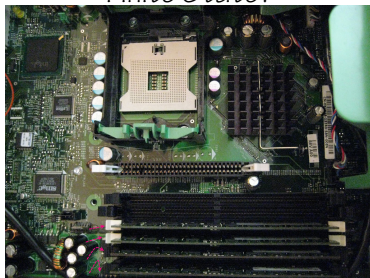

<http://www.flickr.com/photos/cambodia4kidsorg/3019948738>

DETERMINISTIC FINITE STATE MACHINES (DFAs)

Every state has one transition for every possible input symbol.
Often represented graphically:

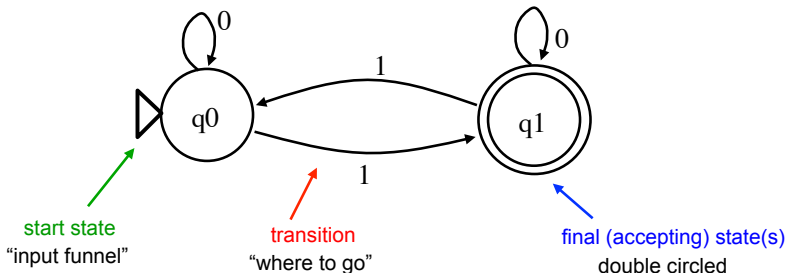

Does this machine accept 100? 1010?

What is the language of this machine?

Finite states = finite memory. What are we “remembering” in each state?

DFAs ARE EVERYWHERE!

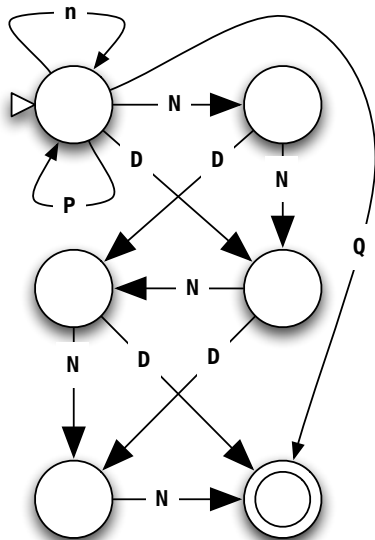

DFAs ARE EVERYWHERE!



DFAS ARE EVERYWHERE!



FSM == FearSoMe?

The FSM controlling
Shambler monsters...

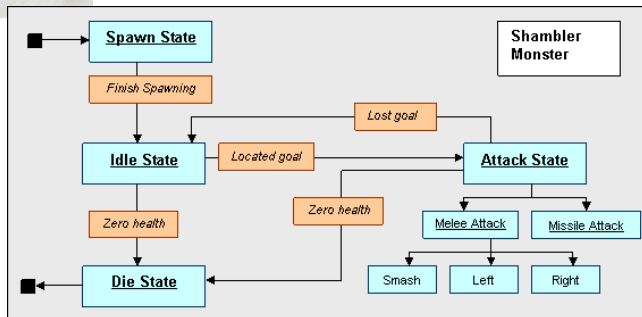

I'm *Quaking* in
my AstroBoots



DFAs ARE EVERYWHERE!

Computers: State changes over time

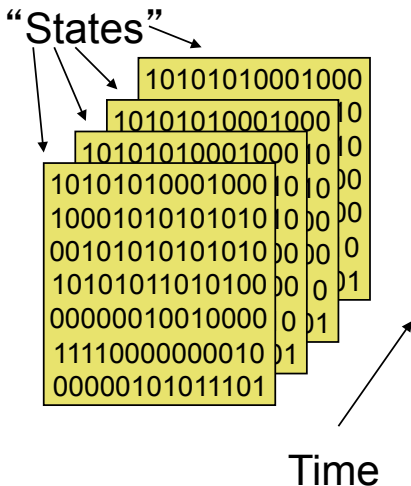

ANOTHER DFA

What is the language of this machine?

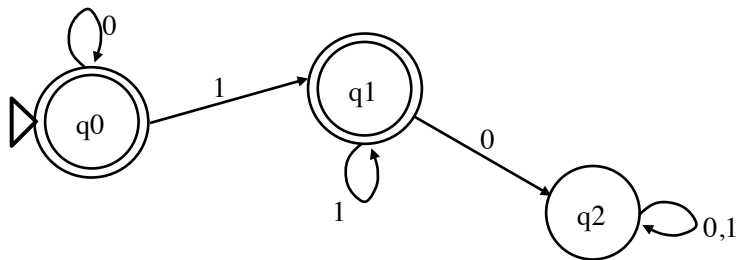

Finite states = finite memory. What are we “remembering” in each state?

EXERCISE

What DFA accepts

$$L = \{w \mid \text{the \# of 1's in } w \text{ is evenly divisible by 4}\}$$

A Common Answer:

“I understood the examples, but I’m not sure how to start”

Suggestions:

- ✓ List a couple strings in L
- ✓ List a couple strings not in L
- ✓ What states will we need? What will they *mean*?
- ✓ Start sketching...

JFLAP!

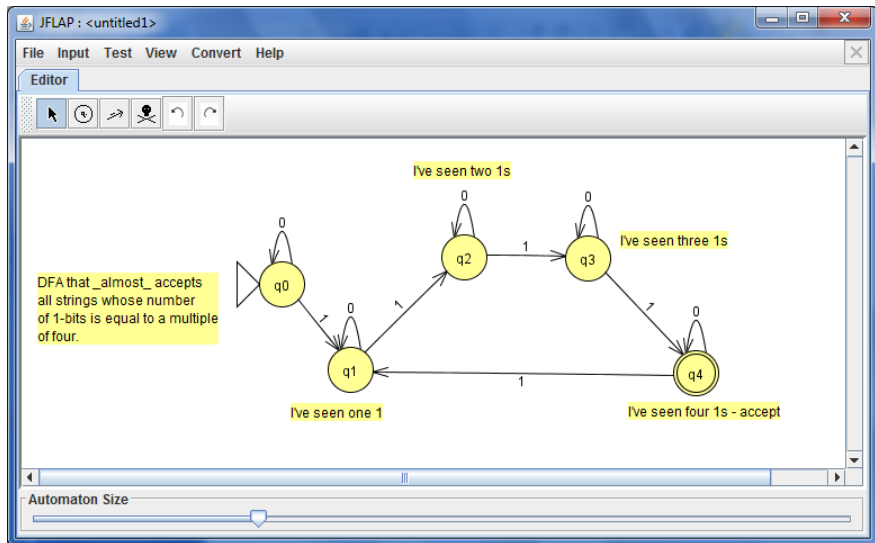

Note: there's a bug in this answer. It's also not minimal.

“QUIZ”

NAME:

1. Draw a DFA accepting
 $\{ w \mid w \text{ is the string } 01 \}$

2. Draw a DFA accepting
 $\{ w \mid w \text{ is a binary power of } 2 \}$

initial 0's are OK
all 0's are **not** OK

3. Draw a DFA accepting
 $\{ w \in \{0, 1\}^* \mid w \text{ is a binary number that's even} \}$
initial 0's are OK

4. Draw a DFA accepting
 $\{ w \mid \text{first \& last bit of } w \text{ aren't different} \}$

101
00
0010
0
1
ε
1001111
:
:

MORE EXAMPLES

What DFA accepts $L = \{ w \in \{0, 1\}^* \mid w\text{'s } \mathbf{third} \text{ character is a } 1 \}$?

MORE EXAMPLES

What DFA accepts

$L = \{w \in \{0, 1\}^* \mid w\text{'s third-to-last character is a } 1\}$?

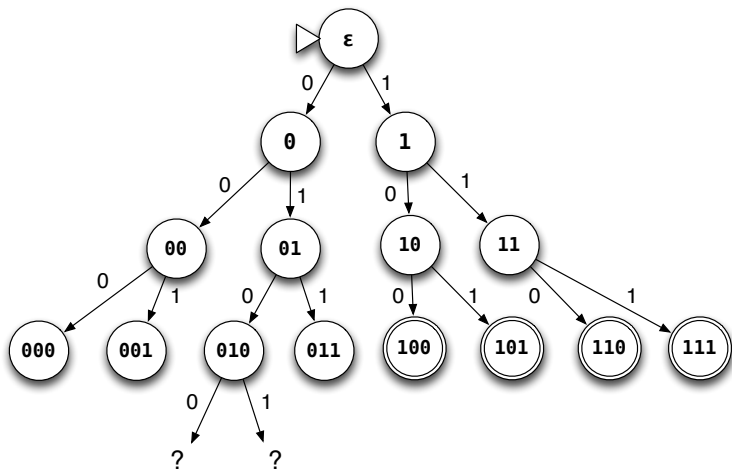

MORE EXAMPLES

What DFA accepts

$L = \{ w \in \{0, 1\}^* \mid w\text{'s third-to-last character is a } 1 \}$?

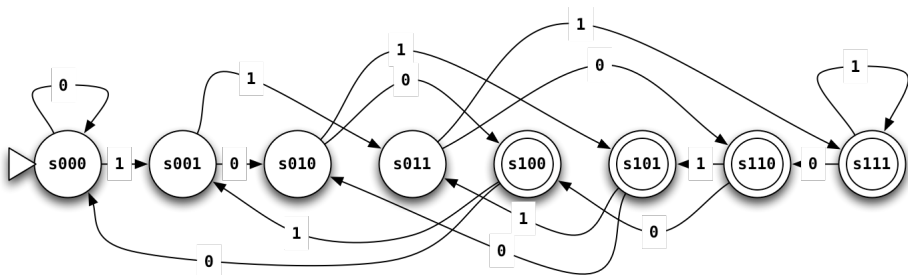

DFA SIZES

How can we know whether a DFA is as small as possible?

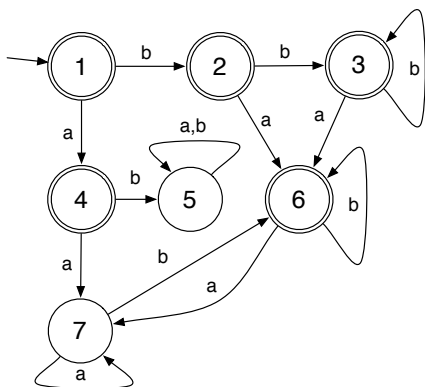
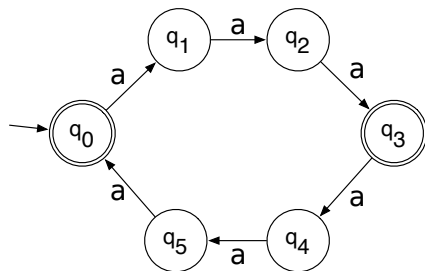

A DFA is minimal if every state is necessary (all states are distinguishable)

THE PLAN

1. Given languages, find *lower bounds* on the number of states in any corresponding state machine.
 - ▶ E.g., $\{ a^{3n} \mid n \geq 0 \}$ requires at least 3 states.
 - ▶ E.g., $\{ w \in \{0, 1\}^* \mid w\text{'s } \mathbf{third-to-last} \text{ character is a } 1 \}$ requires at least 8 states.
2. Find languages requiring $\geq \infty$ states
(are accepted by no *finite* state machine).
3. If computers are finite state machines,
no computer can solve those problems!